

Pipe Floats

SL-PF Series



The Sealite Advantage

- Strong, rotationally moulded polyethylene construction
- Manufactured in high visibility colors
- Easy to install
- Internal anti-slip mechanism
- Resistant to sea conditions
- Optional solar marine light for night visibility
- Available in four sizes: 8, 10, 12, 24 inches

Sealite pipe floats are rotationally moulded from UV-stabilized polyethylene, and can be secured around pipes, hoses and cables for use in dredging or other marine environments such as dredging.

Each kit comes in two halves with associated hardware, and is stackable for storage or within a shipping container for economical transportation.

The units have a number of convenient features including tapered internal ends to allow the pipe to flex, and an internal anti-slip mechanism. As an option, the floats can be filled with closed-cell polyurethane foam to prevent water ingress in the unlikely event of damage.

The float is also designed to accommodate a solar marine light for night-time visibility.

Pipe Floats

Model	Pipe clamp OD (mm/inches)	Pipe clamp ID (mm/inches)	Suitable pipe OD	Length (mm/inches)	Mass (kg/lbs)	Reserve Buoyancy to full submergence (kg/lbs)
SL-PF08	460 / 18	225 / 8 $\frac{1}{2}$	8 inches	900 / 35 $\frac{1}{2}$	Unfoamed: 19.05 / 42.0 Foamed: 22.32 / 49.2	85 / 187
SL-PF10	610 / 24	276 / 10 $\frac{3}{4}$	10 inches	1066 / 42	Unfoamed: 23.5 / 51.8 Foamed: 30.26 / 66.7	199 / 438
SL-PF12	812 / 32	320 / 12 $\frac{5}{8}$ / ₃₂	12 inches	1016 / 40	Unfoamed: 17.71 / 39.15 Foamed: 24.24 / 53.5	372 / 820
SL-PF24	1181 / 46.5	632 / 24 $\frac{1}{2}$	24 inches	1143 / 45	Unfoamed: 52.76 / 116.3 Foamed: 79.76 / 175.8	784 / 1728



Environmentally Friendly & Recyclable

Sealite buoy products are made from recyclable materials. As a service to customers, individual components and products at the end of their service life may be returned to Sealite for recycling.



Pipe Floats

SL-PF Series



SL-PF08

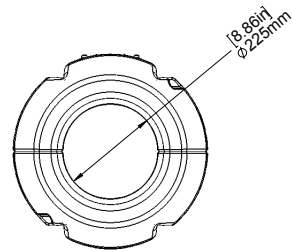
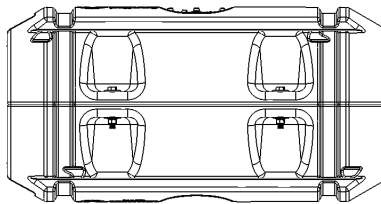
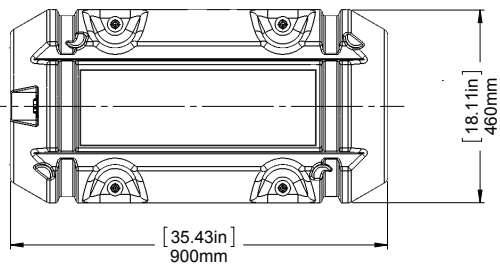

Base Model

SL-PF10

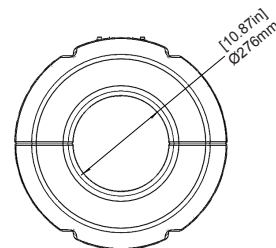
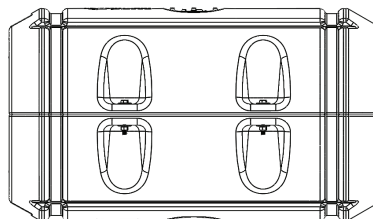
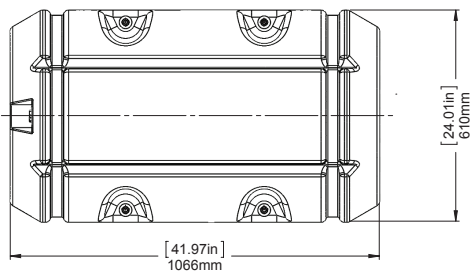

Base Model

SL-PF12

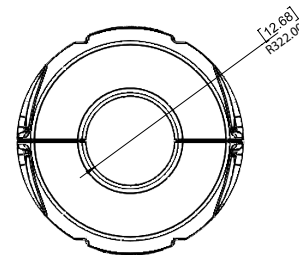
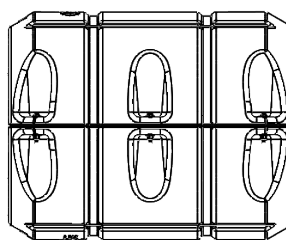
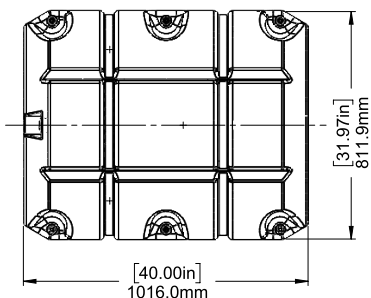

Base Model

SL-PF24

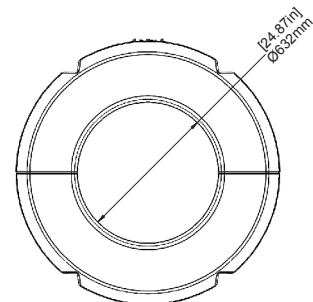
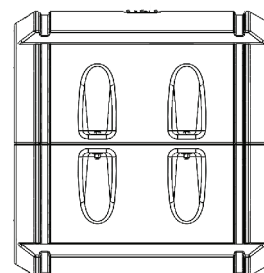
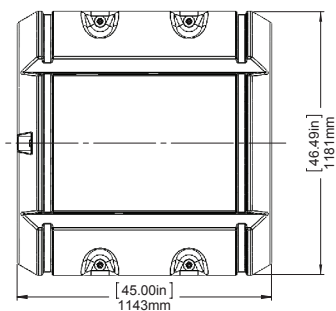

Base Model

• Specifications subject to change or variation without notice
 * Subject to standard terms and conditions
 † Intensity setting subject to solar availability



Sealite Pty Ltd
 Australia
 t: +61 (0)3 5977 6128

Sealite Asia Pte Ltd
 Singapore
 t: +65 6829 2243

Sealite United Kingdom Ltd
 UK
 t: +44 (0) 1502 588026

Sealite USA LLC
 USA
 t: +1 (603) 737 1311