

# 1-2NM+ Solar Marine Lantern

## SL-15

The Equipment complies with requirements of the US Coast Guard in 33 CFR part 66 for private aid to navigation.

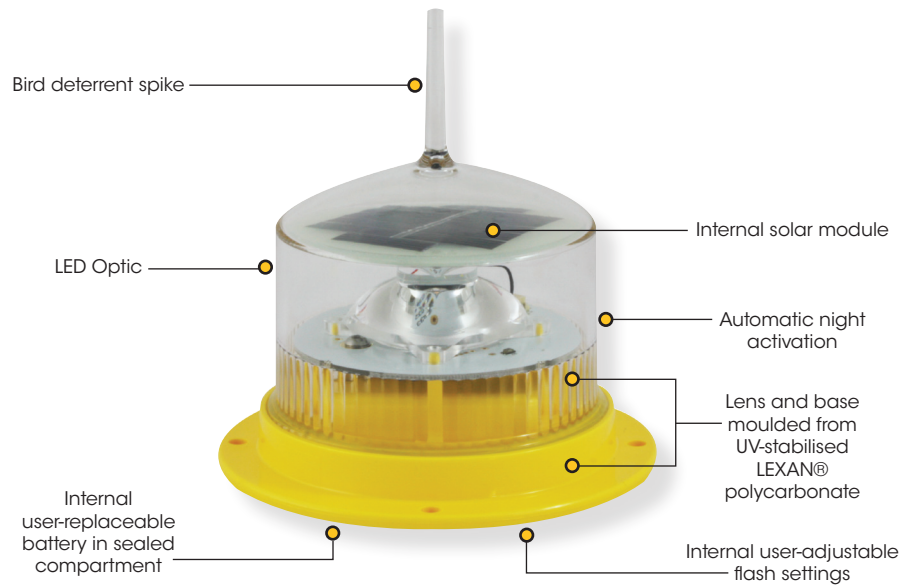

### The Sealite Advantage

- User-adjustable flash characters
- User-replaceable battery in sealed battery compartment
- NiMH battery for long service life & wide temperature range
- Completely sealed & self-contained using advanced UV-sealing
- Installs in minutes & operates maintenance-free for up to five years
- IP68 waterproof

The Sealite SL-15 1-2NM+ compact LED light is exceptional value and incorporates some of the most advanced technology available. In the tradition of Sealite lanterns, the SL-15 is designed to be maintenance-free and have a service life of over 5 years.

The SL-15 can be installed in minutes and requires no operator intervention. The SL-15 has a rotary switch to allow users to change the flash character of the light without the need for special tools or programmers.

During daylight hours the solar module will charge the battery, and the lantern will automatically begin operation at dusk – once the ambient light threshold drops sufficiently.

The SL-15 features Sealite's Single LED Optic which boasts exceptional power to light output efficiency. The tough outer polycarbonate lens incorporates an environment-friendly spike – deterring unwelcome bird life.

The internally housed battery is user-replaceable after years of reliable service.

The unit is sealed using advanced UV-sealing, enabling a rugged and completely waterproof seal capable of prolonged and deep immersion (IP68).

#### Optional ON/OFF Switch

The SL-15 is also available with an optional ON/OFF switch for temporary installations such as worksites.



Sealite Pty Ltd  
Australia  
t: +61 (0)3 5977 6128

Sealite Asia Pte Ltd  
Singapore  
t: +65 6829 2243

Sealite United Kingdom Ltd  
UK  
t: +44 (0) 1502 588026

Sealite USA LLC  
USA  
t: +1 (603) 737 1311



# 1-2NM+ Solar Marine Lantern

## SL-15

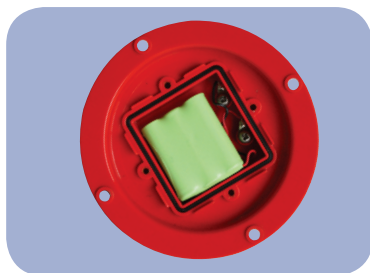

User-replaceable battery

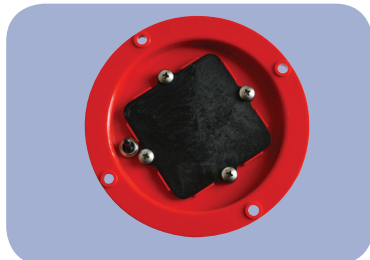

SL-15 with optional ON/OFF switch

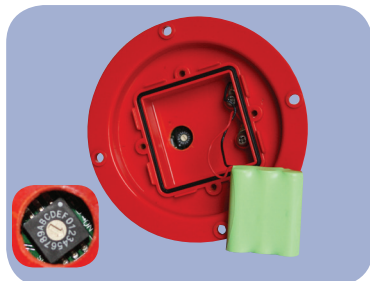

Flash characteristic is selected via internal rotary switch located in the battery compartment

### User-Adjustable IALA Flash Characteristics

FLASH SETTING CODE	Flash Sequence (on, off, on...)
0	STEADY LIGHT (intensity reduced)
1	0.5, 1.0
2	0.5, 3.5
3	1.0, 3.0
4	0.5, 5.5
5	0.3, 0.7
6	0.3, 0.7, 0.3, 0.7, 0.3, 0.7, 0.3, 15.7
7	0.3, 1.7
8	0.3, 2.2
9	0.5, 2.0
A	0.3, 2.7
B	0.5, 2.5
C	0.7, 2.3
D	0.5, 4.5
E	1.0, 4.0
F	Custom Setting

Other flash patterns are available on request

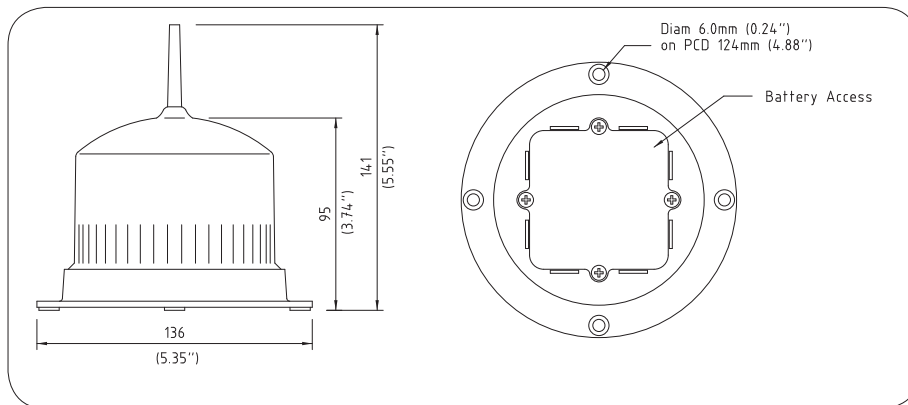

## SPECIFICATIONS\* SL-15

### Light Characteristics

Light Source  
Available Colours  
Typical Maximum Intensity (cd)†  
Visible Range (NM)

Horizontal Output (degrees)  
Vertical Divergence (degrees)  
Reflector Type  
Available Flash Characteristics

Intensity Adjustments

LED Life Expectancy (hours)

### Electrical Characteristics

Current Draw (mA)  
Circuit Protection  
Nominal Voltage (V)  
Autonomy (days)  
Temperature Range

### Solar Characteristics

Solar Module Type  
Output (watts)

### Power Supply

Battery Type  
Battery Capacity (Ah)  
Nominal Voltage (V)

### Physical Characteristics

Body Material  
Lens Material  
Lens Diameter (mm/inches)  
Lens Design  
Mounting  
Height (mm/inches)  
Width (mm/inches)  
Mass (kg/lbs)  
Product Life Expectancy

### Certifications

CE  
IALA  
Quality Assurance  
Waterproof  
IP68

### Intellectual Property

Patents  
Trademarks  
SEALITE® is a registered trademark of Sealite Pty Ltd  
3 years

### Warranty\*

### Options Available

LED

Red - 6.2 Green - 7.6 White - 6.8 Yellow - 5.9

AT @ 0.74: 1-2+  
AT @ 0.85: 1.1-2.3+

360

7

Single LED Optic

16 user-adjustable IALA flash characteristics (other flash patterns available on request)

32 automatic step-down settings based on power demand of flash code selection

>100,000

Refer to Sealite Power Calculator

Integrated

3.6

>50 (14 hour darkness, 12.5% duty cycle)

-40 to 80°C

Multicrystalline

0.45

High grade NiMH

2.4

3.6

LEXAN® Polycarbonate - UV-stabilised

LEXAN® Polycarbonate - UV-stabilised

98 / 3 7/8

Single LED Optic

4 x 6mm mounting holes

141 / 5 1/2

136 / 5 3/8

0.5 / 1 1/8

Up to 12 years

EN61000-6-3:1997. EN61000-6-1:1997

Signal colours compliant to IALA E-200-1

ISO9001:2008

IP68

US Pat. No. 6,667,582. AU Pat. No. 778,918

SEALITE® is a registered trademark of Sealite Pty Ltd

3 years

• ON/OFF switch

• Custom flash patterns

• 50mm pole mount adapter plate



\* Specifications subject to change or variation without notice

† Subject to standard terms and conditions

‡ Intensity setting subject to solar availability

**Sealite**  
www.sealite.com



**IALA**

Sealite Pty Ltd  
Australia  
t: +61 (0)3 5977 6128

Sealite Asia Pte Ltd  
Singapore  
t: +65 6829 2243

Sealite United Kingdom Ltd  
UK  
t: +44 (0) 1502 588026

Sealite USA LLC  
USA  
t: +1 (603) 737 1311