



GSM Cell-Phone Monitoring & Control System Owner's Manual

Version No.	Description	Date	Author	Approved
1.0	Manual Launch	July 2006	C. Procter	
1.1	Addition of active current feature	Nov 2007	J. Procter	
1.2	Addition of new G24 features	Jan 2009	A. Burns	
1.3	Update warranty listing	May 2009	K. Paton	
1.4	Added get & set applications	Aug 2009	A. Dixon	
2.0	Addition of new Q2687 features	March 2012	A. Burns	
2.1	Web Report Update	April 2012	K. Paton	
3.0	Update to GSM Portal	Sept 2012	Y. Chambers	
4.0	Update to screen captures	Feb 2014	Y. Chambers	
4.1	Appendix: Wiring diagrams	August 2015	Y. Chambers	
5.0	Update web reporting number	October 2015	Y. Chambers	
5.1	Update: Contact details	April 2016	J. Dore	
5.2	Update Commands, Update Alarms for GSM, Update Installation details for SIM Card,	September 2016	A. Dixon	M.Nicholson

Disclaimer:

It is the customer's responsibility to check with their service provider (prior to installation) to ensure there is network coverage in the area in which the lantern(s) will be installed. Sealite Pty Ltd will not be held responsible if the network coverage of the service provider should fail.

Table of Contents

Introduction	Page 4
System Components	Page 5
Getting Started: Setting up your GSM Module	Page 6
Step 1: Purchase, Record & Insert SIM Card into Lantern	Page 7
Step 2: Program Cell Phone Access List, Web Reporting & Essential Commands	Page 9
Step 3: Program Desired Cell Phone Report List & Alarms	Page 12
Accessing your Lantern’s Data	Page 16
The add Command	Page 18
The list Command	Page 20
The delete Command	Page 21
The get Command	Page 22
The set Command	Page 23
Step 4: Accessing the Sealite GSM Web Portal	Page 26
CREATE A GSM ACCOUNT	Page 26
GSM Dashboard	Page 29
CONFIGURATION	Page 30
DEPLOYMENT MAP	Page 41
REQUEST HELP	Page 43
CHANGE PASSWORD	Page 45
Lantern Installation Location	Page 47
Trouble Shooting	Page 49
Trouble Shooting Table	Page 50
Lantern Board Indicator / Status LEDs	Page 51
Phone Module Indicator / Status LEDs	Page 52
Appendix	Page 54
Wiring Diagrams	Page 55
Sealite Lantern Warranty	Page 57



Introduction

Welcome to GSM monitoring and control of your marine lanterns. The Sealite GSM Monitoring and Control System is a complete integrated module designed to allow convenient monitoring of Sealite lanterns using a cellular telephone and web access from remote locations that have GSM network coverage.

The GSM circuit monitors the data from the lantern and will report to designated cell phones a number of pre-programmed alarm conditions if they occur.

The GSM System is internally housed within the Sealite lantern and requires no external aerials – providing convenient installation and retaining the IP68 waterproof rating of the lantern.

The user can also send an SMS text message to the designated Sealite lantern to receive a status report from the lantern by return SMS text message. In addition, the user has complete control over the types of alarms received should a fault occur, as well as an array of remote control options including operational mode, flash code and intensity settings.

The user can also set the lantern up to regularly report to a secure area of the Sealite website (the Sealite web gateway). This will provide details of your lanterns operation and it's GPS position and includes historical graphed statistics of each lantern.

All functions can be programmed into the remote lantern by sending an appropriate SMS text message from a designated cell phone.

Tracking a drifting buoy or alerting to a potential power disruption has never been easier.

The Sealite GSM Monitoring and Control System is secure – unauthorised access to the lanterns data cannot occur as only the designated cell phone numbers programmed into the light will respond to a remote SMS text message.

Data transferred to and maintained on the Sealite website is user password protected.

Key Features:

- Access of current lantern status at any time by sending an SMS text message to the lantern from any designated cell phone number. The lantern status is sent by return SMS text message;
- Regular reporting of lantern status to designated cell phone numbers and/or web server;
- Reports any pre-programmed alarm condition to designated cell phone numbers, and/or email addresses;
- Remote control of lantern features by sending an SMS text message to the lantern including flash & intensity setting and operation mode;.
- Versatile configuration allows lanterns with or without GPS modules fitted to be monitored remotely.

Available Data from Remote Lantern:

- Battery voltage
- Solar module charging current
- Lantern current draw
- Lantern position - Latitude and Longitude (including 'off-station' facility)
- Day/night on status
- Current operation mode
- Current flash code setting
- Current intensity setting

System Components

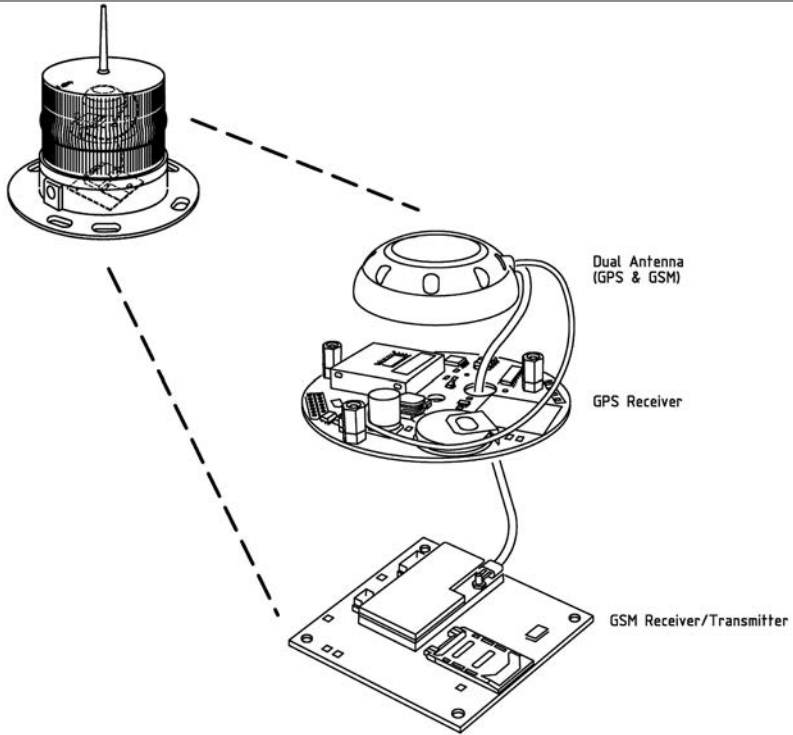

All components of the GSM Receiver / Transmitter are enclosed within the Sealite lantern body.

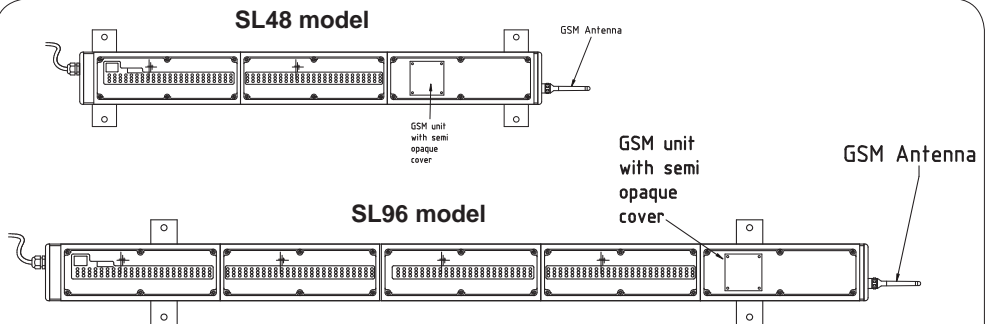

The SL48 & SL96 models have the components of the GSM Receiver / Transmitter enclosed within the top module of the light and have an external aerial.



Getting Started: Setting up your GSM Module

Setup of the Sealite GSM Monitoring and Control System is a simple 4-step process, outlined below;

STEP 1:

**Purchase, Record and Insert
SIM Card into GSM Lantern**

- Similar to a cell-phone, a valid SIM card needs to be acquired and inserted into the GSM module prior to use (see “Purchasing a SIM Card” section of this manual). Refer to *Installing the Sim Card* section of this manual for a step-by-step guide to installing your SIM card.

STEP 2:

**Program Cell Phone Access
List, Web Reporting and
Essential Commands**

- The access list is a list of cell phone numbers from which the Sealite GSM Monitoring and Control System will accept configuration commands and report requests. Web reporting and essential commands may also be setup at this step.

STEP 3:

**Program Desired Cell Phone
Reporting List and Alarms**

- The report list is the list of cell phone numbers which the lantern may send any SMS text message alarm report to. Alarm emails may also be activated from Sealite’s secure GSM Web Portal.

STEP 4:

**Accessing the Sealite
GSM Web Portal**

- By sending a report to the Web gateway and providing access via the Sealite website, historical data and graphs may be viewed on each lantern.



**GSM Monitoring & Control
System Ready for Operation**

STEP 1: Purchase, Record and Insert SIM Card into GSM Lantern

Purchasing a SIM Card and Recording Details



Ensure the SIM card is unlocked prior to installing into the lantern.

One SIM card is required per lantern and can be purchased from your local telecommunications dealer. You may decide to purchase a pre-paid SIM card, or set the SIM card up on a plan (this is similar to purchasing a new cell phone).

Sealite's GSM enabled lanterns require a Mini-SIM or 2FF SIM Card with a 6 pin contact arrangement.



RIGHT:
Mini-SIM or 2FF SIM Card (2nd Form Factor)
- 6 pin contact arrangement



WRONG:
- 8 pin contact arrangement

Each lantern with GSM Monitoring and Control System will have an individual cell phone number. This number is unique to the lantern and should be recorded for reference purposes against the lantern it is installed in. To assist in recognition it is advisable that a description be included as well as the number (For example, Port Beacon #12, +61400123456). A similar recording in user cell phones will assist in identifying lantern installations to which SMS text message commands are sent (the same process as adding a new contact in your cell phone address book).

Installing the Sim Card



Pic 1.

1. Remove the 6 retaining screws from the cover on the underside of the light, to gain access to the GSM compartment.
2. Open the SIM Card holder.



Pic 2.

3. Position the SIM into the holder. Make sure the SIM Card is positioned correctly. Make sure the SIM Card is 'Unlocked' before inserting in the holder (ie. the SIM card password has been disabled).



Pic 3.

4. Fold the SIM Card holder and push it forward into the closed position
5. Replace the 6 retaining screws to close the GSM compartment. Make sure the rubber seal is positioned correctly before fitting the cover.

STEP 2:

Program Cell Phone Access List, Web Reporting & Essential Commands

The Access List is a list of cell phone numbers from which the Sealite GSM Monitoring and Control System will accept configuration commands and report requests. Web reporting and essential commands may also be setup at this step.

Follow the process below to program the Access List, Web Reporting and Essential Commands;

Select a cell phone from which the GSM Monitoring and Control System module will be activated.

- The lantern will accept the first cell phone contact for instructions.
- The first instruction must be correct as the lantern will then only respond to the access cell phone number(s) given.

*Two numbers should be provided to the lantern to ensure there is a backup access**.*

Add cell phone numbers to the permitted access list by sending the SMS text message:-

add access +(country code)(phone number)

More than 1 cell phone number can be included in the SMS text message. To do this separate each cell phone number with a 'comma' character.

- "+" and the country code (eg. 61 for Australia, or 44 for U.K) are required to establish the country prefix in which the GSM unit is to operate in. Additional cell phone numbers can then be added by sending commands from those numbers given access.
- For example, to add an Australian cell phone number to the access list the SMS text message command would be:
add access +61400987654

All additional telephone numbers added to the access list must be in the international format.

- Once the number has been added to the access list the Sealite GSM Monitoring and Control System will accept commands from these numbers and acknowledge confirmation via reply SMS text message.
- This command initiates the daily web reporting, which sends a daily diagnostic update to be viewed from your secure login at the Sealite Website.

Enable web reporting by sending the SMS text message:-
add autoreport web
or
add alarm web

Only phone numbers listed in the Access List will be able to "Set" and "Get" lantern information.

**In the event that the access cell phone number(s) is lost or no longer in service, Sealite can reset the lantern from the factory if required.

From an authorized Access Cell Phone send a new SMS with text message 'status' or 'report' to the designated SIM card number of your GSM lantern.

Within a few minutes expect a reply in similar format as the following:

Status Report

Volts: 14.1V

Charge: 0.33A

Mode: Dusk to Dawn

FCode: 051

Night

Lat: 38 13.2988 S (Latitude 38° 13.2988')

Long: 145 10.8529 E (Longitude 145° 10.8529')

OnStation

Note: The actual layout of the message is dependent on your cell phone screen.

User Case #1: Setting up the lantern to report an alarm to a cell phone

In this example, a cell phone with the phone number +61491570166 is used to enable the alarm function *low battery*. When the alarm condition occurs, the lantern will alert cell phone +61491570156.





Note: it is allowable to assign a different cell phone number to receive the alarm reports.

The following messages will be texted to the lantern:

add access +61491570166

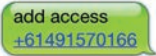
add report +61491570156

add alarm batlo

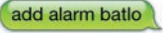
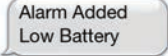
	SMS text message to Lantern	SMS text message received on cell phone	Comment
Step 1			Configures the lantern to allow commands Note: The cell number must be formatted as: +(country code)(phone number)
Step 2			When an alarm condition occurs, a text message will be sent to phone number. Note it is allowable to assign a different cell phone number to receive the alarm reports.
Step 3			The lantern will send a text message to all phone numbers in the report list when the battery voltage falls below 11.7V.

User Case #2: Setting up the lantern to report to the Sealite web gateway





In this example, a cell phone with the phone number +61491570166 will configure the lantern to send daily reports to the Sealite web gateway (+61418569242).

The following messages will be texted to the lantern:

add access +61491570166

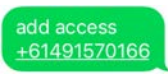
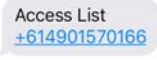
add web +61418569242

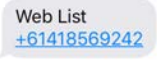
add autoreport web

	SMS text message to Lantern	SMS text message received on cell phone	Comment
Step 1			Configures the lantern to allow commands Note: The cell number must be formatted as: +(country code)(phone number)
Step 2			When an alarm condition occurs, a text message will be sent to the Sealite web gateway. This the phone number for Sealite's web gateway.
Step 3			Enables a daily web report to be sent to the Sealite web gateway number

Notes:

1. In order to view web reports, please refer to "Accessing the Sealite Web Reports" section of this manual.
2. If the lantern is located outside of Australia, the lantern's SIM card will need permission to be send text internationally. Please consult with your SIM card provider to ensure that this feature is enabled.

STEP 3: Program Desired Cell Phone Report List & Alarms

An alarm is an SMS text message which is sent after a preset alarm condition programmed into the lantern is triggered. Care should be taken when selecting suitable alarms as they can generate large numbers of SMS text messages if not carefully selected.

The report list establishes the cell phone numbers that the alarms will be sent to.

Programming Report List

The following process will create a list of approved cell phone numbers from which desired alarm reports will be sent;

Use a cell phone in the access list to create the report list by sending the SMS text message:-

add report +(country code)(phone number)

More than 1 cell phone number can be included in the SMS text message. To do this separate each cell phone number with a 'comma' character.



A successful update will result in an SMS text message reply:-

**Report List
+(designated cell phone numbers)**

The designated cell phone number has now been added to the 'report' list. The Sealite GSM module will now accept an SMS text message request for status 'report' from this number.

- This creates an authorised list of cell phone numbers belonging to staff, on-call company maintenance officers or contractors.

- For example, to add an Australian cell phone number to the report list the SMS text message command would be:
add report +61400987654

- The SMS text message 'report' sent from on-call company maintenance officers or contractors in this list will now generate the standard report SMS text message reply from the lantern.

A typical response SMS text message report message from a lantern will display as below:

List Report
+61400111222

Note: The actual layout of the message is dependent on your cell phone screen.

Creating Individual Alarms to be sent to the Cell Phone Report List

Specific alarms can be created and sent as an SMS text message to cell phones listed in the Report List.

The following process will enable desired alarms;

Use a cell phone in the access list to enable desired alarms by sending the SMS text message:-

add alarm (alarm parameter)

More than 1 alarm can be included in the SMS text message. To do this separate each alarm parameter with a 'space' character.

- An example of an actual alarm SMS text message would be:

add alarm batlo

- This sets the low battery alarm. No cell phone number is required following the SMS text message

A successful update will result in an SMS text message reply:-

Alarm Added
(list of all alarms currently setup)

- A successful update of the above example would result in a reply SMS text message:

Added Alarm
Low Battery

A typical response SMS text message report message from a lantern when alarms are set up will display as below:

Alarm Added
Low Battery
Web Report

Note: The actual layout of the message is dependent on your cell phone screen.

Once an alarm condition has occurred/been triggered an SMS text message will be sent reporting the alarm to all cell phone numbers listed in the "Report List" and/or to the email addresses listed in the enabled "Alarm Emailing List" from the Sealite GSM Web Portal. Alarm conditions will continue to be reported once every 24 hours. This is to prevent constant reporting of the same alarm or multiple alarms. The lantern can still be accessed by requesting a report via SMS text message.

Alarm Sources Summary

All of the following alarm conditions can be programmed via SMS text message to be either ENABLED or DISABLED.

If an alarm condition that has been enabled occurs, an SMS text message will be automatically sent to all the cell phone numbers listed in the Report List.

Command	Parameter	Function	Enable Command Format	Disable Command Format
add alarm	batlo	Alarm SMS "batlo" is asserted when the battery voltage falls to a low level (flat battery). An alarm condition will be set if the system battery voltage falls below 10.0V indicating a flat battery. The lantern will be turned OFF if the battery voltage falls below 10.0V.	add alarm batlo	delete alarm batlo
	nodata	Alarm SMS "nodata" is asserted when the GSM module loses communication with the lantern circuitry.	add alarm nodata	delete alarm nodata
	LED Failure	Alarm SMS LED Failure is asserted when an individual LED in the lantern fails and the lantern sends a signal to the GSM. NOTE: only available on certain lanterns.	add alarm ledfail	Delete alarm ledfail
	rotation	Alarm SMS Rotation is asserted when the external rotation sensor detects a failure in a 3rd Party Rotating Table. The Lantern sends a signal to the GSM. NOTE: only available on certain lanterns	add alarm rotation	Delete alarm rotation
	temp	Alarm SMS Temp is asserted when an Internal or External Temperature Sensor falls out of a pre-set boundary and the lantern sends a signal to the GSM. NOTE: only available on certain lanterns.	add alarm temp	Delete alarm temp
	Mains fail	Alarm SMS Mains Fail is asserted when AC power is disrupted and the lantern sends a signal to the GSM. NOTE: only available on certain lanterns	add alarm mains	Delete alarm mains

Command	Parameter	Function	Enable Command Format	Disable Command Format
Daily Reporting Alarms				
add alarm / add autoreport	daily	Enables a daily 'status' report from the lantern to be sent to all cell phone numbers in the report list. This report occurs 4 hours after daybreak each day.	add alarm daily or/ add autoreport status	delete alarm daily or/ delete autoreport daily
	power	Enables a battery report to be sent daily to all cell phone numbers in the report list. This report occurs 4 hours after daybreak each day.	add alarm power or/ add autoreport battery	delete alarm power or/ delete autoreport battery
	web	Enables a daily web report to be sent to Sealite's GSM Web Portal, web gateway numbers in the web list. This report occurs 4 hours after daybreak each day.	add alarm web or/ add autoreport web	delete alarm web or/ delete autoreport web
ALARMS AVAILABLE FOR GPS ENABLED LANTERNS ONLY				
add alarm	nogps	Alarm SMS "nogps" is asserted when the GPS data is not available - usually due to GPS signal loss.	add alarm nogps	delete alarm nogps
	offstation	Alarm SMS "offstation" is asserted when the GPS position differs from the recorded station position by more than 200 meters.	add alarm offstation	delete alarm offstation

Offstation Alarm SMS Text Message

When the buoy moves outside the designated boundary an automatic SMS text message will be sent to all the cell phone numbers in the report list. The designated boundary radius is factory set to 200m, and the GPS station position is automatically set by the lantern. The SMS text message report message from a lantern will display as below:

ALARM Offstation

**Lat: 38 13.2175S,
Long: 145 10.8375E,**

Note: The actual layout of the message is dependent on your cell phone screen.



Accessing Your Lantern's Data

A) Via Cell Phone

General data about the lantern is accessed via simply sending the SMS text message; 'status' or 'report' from an authorized cell phone number (must be listed in the 'access' list or 'report list') to the designated lantern's SIM card number.

An automatically generated reply SMS text message will then be sent to your cell phone which includes information about the lantern status.

1. A typical requested SMS text message report from a lantern will display as below; 'status' or 'report'

Status Report

Volts: 14.1V
Charge: 0.33A
Mode: Dusk to Dawn
FCode: 051
Night
Lat: 38 13.2988 S (Latitude 38° 13.2988')
Long: 145 10.8529 E (Longitude 145° 10.8529')
OnStation

*Note: The actual layout of the message is dependent on your cell phone screen.
If the lantern is not fitted with GPS the message "No GPS Data" will be given in place of the GPS data*

2. Specific battery data from your lantern is accessed via the SMS text message; 'power' or 'battery'

Power Report:
Battery: 14.2V
Charge: 0.24A
Load: 0.02A

Yesterday
Min: 14.1V
Max: 14.3V
Max Solar: 0.36A
Charge: 1.76Ah
Load: 0.56Ah

*Note: The actual layout of the message is dependent on your cell phone screen.
Ah = Ampere Hours = current x time (24 hour running).
Yesterday's power data is only available if the GSM has been running for more than 24 hours.*

3. A more detailed report from the lantern is available by sending the SMS text 'status full'.

This will result in your lantern sending 4 x SMS replies to your phone

Extended Status

Volts: 14.1V

Charge: 0.33A

Mode: Dusk to Dawn

FCode: 051

Night

Lat: 38 13.2988 S (Latitude 38° 13.2988')

Long: 145 10.8529 E (Longitude 145° 10.8529')

OnStation

Product ID: SLLEDCTRL (Example only)

Product Name: Sealite Test Sample (20 Character Limit)

Colour: White

Status Flags: 00018

Temperature Sensor: OK

Lantern Temperature: OK

Intensity: 100%

Adv Op Mode: All

Sync Offset: 0.0s

GPS Mode Normal

GPS Watch Circle: 200m

Lantern Voltage: 14.1V

Lantern Battery: OK

GSM Voltage: 13.9V

GSM Battery: OK

GSM Mode: Normal

GSM Carrier: Telstra

GSM Signal: Max

Triggered Alarms: None

Note: The actual layout of the message is dependent on your cell phone screen.

If the lantern is not fitted with GPS the message "No GPS Data" will be given in place of the GPS data

This message is requires 4 x Text Messages to be sent. There may be cost implications depending on your Sim Card Phone Plan.



4. Via Sealite GSM Web Portal

To configure your GSM lantern to send daily reports or alarms to Sealite's secure online GSM Web Portal the following messages **MUST** be sent via SMS text message to your lantern:

"add alarm web"

Then send the SMS text message:

"add autoreport web"

The add Command

The "add" command allows;

- Cell phone numbers to be added to the 'access' and 'report' lists and;
- Required alarms and autoreports to be enabled.

Only users listed in the Access List are able to use the "add" commands

Full cell phone numbers including '+' and country code must be used when adding cell phone numbers to the 'access', 'report' & 'web' lists.

To add the cell phone number 0402123456 to the 'report' list the following command would be sent in an SMS text message from any cell phone number listed in the access list:

"add report +61402123456"

A successful update would result in an SMS text message reply:

**"Report List
+61402123456"**

To add a low battery alarm trigger the following command would be sent in an SMS text message from an authorised cell phone:

"add alarm batlo"

A successful update would result in an SMS text message reply:

**"Alarm Added
Low Battery
No Lantern Data
No GPS Data
Web"**

Command	Parameter	Function	Example Command Format
add	access	Adds additional cell phone number(s) to the permitted access list. More than one cell phone number can be included in the SMS by separating each number with a "comma" character. The same cell phone number may also be programmed into the "report" list. The access list can contain a maximum of 16 cell phone numbers.	add access +61402123456 or/ add access +61402123456, +61402654321
	report	Adds additional cell phone number(s) to the permitted report list. More than one cell phone number can be included in the SMS by separating each number with a "comma" character. The same cell phone number may also be programmed into the "access" list. The report list can contain a maximum of 16 cell phone numbers.	add report +61402123456 or/ add report +61402123456, +61402654321
	alarm / autoreport	Adds the required alarm or autoreport functions that will report to the cell phones in the report list. More than one alarm can be included in the SMS. Separate each alarm condition with a "space" character. Possible alarms are: batlo, nodata, daily, nogps, offstation, web, power Possible autoreports are: status, daily, battery, power, web	add alarm batlo or/ add alarm batlo, nogps or/ add autoreport status

All cell phone numbers must be presented in international format – ie/ In Australia '0402123456' becomes '+61402123456'. In the United Kingdom, '07791234567' becomes '+447791234567'. The maximum phone number can be 15 digits long, if you require more than 15 digits please contact Sealite.

The list Command

The “list” command allows the operator to view:

- Cell phone numbers listed in the ‘access’, ‘report’ and ‘web’ lists and;
- List enabled alarms and autoreports programmed into the lantern.

Only users listed in the Access List are able to use the “list” commands

To determine the cell phone number entries in the ‘report’ list the following SMS text message command would be sent:

“list report”

The GSM Monitoring and Control System would SMS text message a response containing the contents of this list:

**“Report List:
+61402123456,
+61402654321”**

To determine the ‘alarm’ list the following SMS text message command would be sent:

“list alarm”

The GSM Monitoring and Control System would SMS text message a response containing the contents of this list:

“current alarm list: nodata, temphi, nogps, nopps, batlo”

Command	Parameter	Function	Example Command Format
list	access	Requests a list of the current cell phone numbers in the access list. An SMS is returned showing the current access list.	list access
	report	Requests a list of the current cell phone numbers in the report list. An SMS is returned showing the current report list.	list report
	web	Requests a list of the current Sealite web gateway phone number. An SMS is returned showing the current report list.	list web
	alarm / autoreport	Requests a list of the current alarms and autoreports programmed into the alarm list. An SMS is returned showing the current alarm list.	list alarm or/ list autoreport

All telephone numbers must be presented in international format – ie/ In Australia ‘0402123456’ becomes ‘+61402123456’. In the United Kingdom, ‘07791234567’ becomes ‘+447791234567’.

The delete Command

The “delete” command operates in the same way as the “add” command. The difference is the “delete” command will also accept the keyword “all”. This allows the list to be cleared in a single SMS text message.

Only users listed in the Access List are able to use the “delete” commands

To remove the cell phone number 0402123456 from the report list the following command would be sent:

“delete report +61402123456”

A successful deletion would result in an SMS text message reply:

**“Report List
Empty”**

When the report list is “empty”, this means that there are no cell phone numbers in the ‘report’ list, therefore disabling the automatic alarm function.

To remove an alarm from the alarm list the following command would be sent:

“delete alarm batlo”

A successful deletion would result in an SMS text message reply:

**“Alarm Deleted
No Lantern Data
No GPS Data”**

Command	Parameter	Function	Example Command Format
delete	access	Deletes the requested cell phone number from the permitted access list.	delete access +61402123456
	report	Deletes the requested cell phone number from the permitted report list.	delete report +61402123456
	web	Deletes the requested cell phone number from the permitted web list.	delete web +61418569242
	alarm / autoreport	Deletes the requested alarm or autoreport from the current alarm list.	delete alarm batlo

All telephone numbers must be presented in international format – ie/ In Australia ‘0402123456’ becomes ‘+61402123456’. In the United Kingdom, ‘07791234567’ becomes ‘+447791234567’.

The get Command

The “get” command is used to retrieve or “get” information from the lantern.

Information that can be retrieved includes

- Lantern Type
- Software Version
- Flash Code
- Intensity
- Operation Mode

Only users listed in the Access List or Report List are able to use the “get” commands. Some commands are only available to Access List users.

To retrieve the current flash code setting in the lantern, the following command would be sent

“Get fc” or “Get Flashcode” or “Get Flash code”

A successful reply would result in an SMS text message reply:

Lantern Config

Mode: Dusk to Dawn
Flash Code: 051
Intensity: Low

Note: The 51 indicates the flash code as it relates to the sequence found in the Sealite Flash Code Tables. To retrieve the current intensity setting in the lantern, the following command would be sent “Get intensity”

A successful reply would result in an SMS text message reply:

Lantern Config

Mode: Dusk to Dawn
Flash Code: 051
Intensity: Low

Note: The lantern was set to Low intensity

Command	Parameter	Function	Example Command Format	Permission
get	Type	Gets the lantern hardware type	Get type	Report & Access
	Version	Gets the lantern's software version	Get version	Report & Access
	Operation Mode	Gets the lantern's operational mode	Get Mode Get Op	Report & Access
	Fc Flashcode Flash code	Gets the lantern's flash code <i>Note: the lantern will respond to any of the options shown to the left.</i>	Get fc Get flashcode Get flash code	Report & Access
	Intensity	Gets the Lantern's current intensity setting	Get intensity	Report & Access
	gsm mode	Gets the Operational Mode of the GSM module	Get gsmmode	Report & Access
	gps mode	Gets the Lantern's current GPS Operational Mode	Get gsmmode	Report & Access
	sync offset	Gets the Sync Offset as set by the GSM module	Get syncoffset	Report & Access

All telephone numbers must be presented in international format – ie/ In Australia ‘0402123456’ becomes ‘+61402123456’. In the United Kingdom, ‘07791234567’ becomes ‘+447791234567’.



The set Command

The “set” command is used to enter or “set” information on the lantern.

Information that can be set by the user includes

- Operation Mode
- Flash Code
- Intensity

Only users listed in the Access List are able to use the “set” commands

To set a new flash code, the following command would be sent

“Set fc 73” or “Set Flashcode 73” or “Set Flash Code 73” (the flash code used was 7,3 (0.3On, 0.7Off))

A successful reply would result in an SMS text message reply:

Lantern Config

Mode: Dusk to Dawn
Flash Code: 073
Intensity: Low

Note: The 0xx indicates the number is in Hexadecimal Format. Eg. 073

Note: The 73 indicates the flash code as it relates to the sequence found in the Sealite Flash Code Tables

To set a new intensity, the following command would be sent

“Set intensity High”

A successful reply would result in an SMS text message reply:

Lantern Config

Mode: Dusk to Dawn
Flash Code: 073
Intensity: High

The default values for the lantern are:

- Operation Mode – Dusk to Dawn.
- Flash Code – is factory set to 51 via the Rotary Switches.
- Intensity – is factory set to 100% via the DIP Switches.

All telephone numbers must be presented in international format – ie/ In Australia ‘0402123456’ becomes ‘+61402123456’. In the United Kingdom, ‘07791234567’ becomes ‘+447791234567’.

Command	Parameter	Function	Example Command Format	Permission
set	Mode	Sets the lantern's operation mode. <ul style="list-style-type: none"> • Dusk to Dawn, on • Standby, off • Always on 	Set mode Dusk to Dawn Set mode Standby Set mode Always on	Access
	Fc Flashcode Flash code	Sets the lantern's flash code Note: the lantern will respond to any of the options shown to the left. The flash code set by this command will remain active until either a new command is received or the Rotary Switches are changed.	Set fc 51 Set flashcode 51 Set flash code 51	Access
	Intensity	Sets the Lantern's current intensity setting Intensities that can be set are <ul style="list-style-type: none"> • Low • Medium • High The intensity set by this command will remain active until either a new command is received or the DIP Switches are changed.	Set intensity low	Access
	gsm defaults	This resets the GSM settings. It clears the Access and Report number lists and disables all alarms.	Set gsm defaults	Access
	gsm mode	Sets the Lantern's GSM Operational Mode. It alters the power saving strategy.	Set gsmmode slow Set gsmmode normal Set gsmmode always on	Report & Access
	gps mode	Sets the Lantern's GPS Operational Mode. It alters the power saving strategy.	Set gpsmode slow Set gpsmode normal Set gpsmode always on	Report & Access
	sync offset	Sets the Lantern's GPS Sync Offset. If two lantern's are flashing with the same flashcode but need to be distinguished, the GSM Module can offset the Synchronisation of the lantern. The offset is 0 - 300 secs. (0.1 increments) For example if you wish to offset a lantern 1.5 seconds send the following example.	Set syncoffset 1.5	Access

All telephone numbers must be presented in international format – ie/ In Australia '0402123456' becomes '+61402123456'. In the United Kingdom, '07791234567' becomes '+447791234567'.

GPS Mode

To reduce power consumption in your Lantern over a 24Hour period it is now possible to change the number of times the GPS module activates. The default setting is Normal.

Only users on the Access List can change this setting.

GSM & GPS Mode

To reduce power consumption in your Lantern over a 24Hour period it is now possible to change the number of times the GSM module activates.

The default setting is Normal

Only users on the Access List can change this setting

GSM Mode	Battery State	Module Usage
Slow	Normal (> 11.5V)	On for 5 minutes Off for 55 minutes
	Low (10V to 11.5V)	On for 5 minutes Off for 115 minutes
	Flat (<10V)	On for 3 minutes Off for 235 minutes
Normal	Normal	On for 5 minutes Off for 15 minutes
	Low	On for 5 minutes Off for 30 minutes
	Flat	On for 3 minutes Off for 57 minutes
Fast	Normal	On for 5 minutes Off for 5 minutes
	Low	On for 5 minutes Off for 30 minutes
	Flat	On for 3 minutes Off for 57 minutes
Always On	Normal	Always On
	Low	Always On
	Flat	On for 3 minutes Off for 57 minutes

GPS Mode	Description	Example Command Format
Off	The GPS is always off	Set GPS mode off
Normal	The GPS is turned off for 15 minutes (Night) and 30 minutes (Day)	Set GPS mode normal
Fast	The GPS is turned off for 5 minutes (Night) and 10 minutes (Day)	Set GPS mode fast
On	The GPS is always left on	Set GPS mode on

STEP 4: Accessing the Sealite GSM Web Portal

CREATE A GSM ACCOUNT

After daily web reporting has been enabled via SMS text message command and your GSM lantern, access to historical data and graphs about individual lantern installations is available via the Sealite website.

Follow the steps below to access your lantern operational data;

1. Go to www.sealite.com on the internet,
2. Select the Technical tab,
3. Select Create a GSM Account

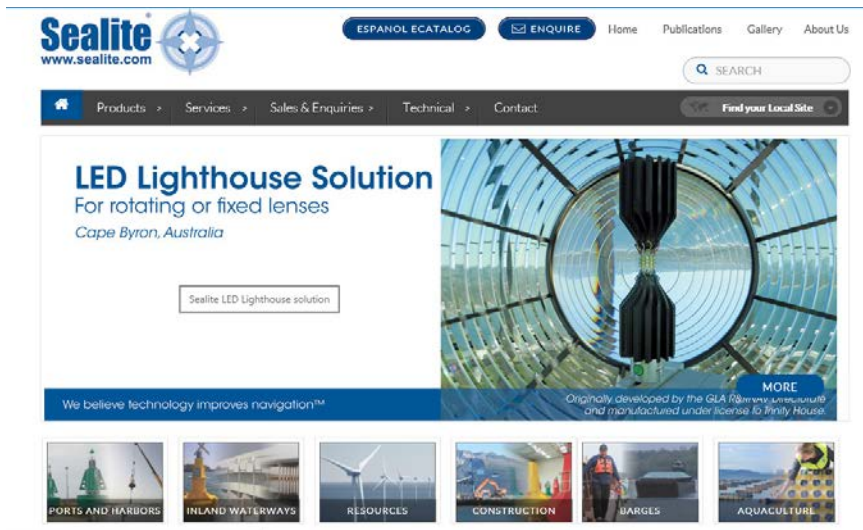

For lantern data to be updated daily in the Sealite GSM Web Reports, users must first send the SMS text message command “add alarm web” to the designated lantern(s).

2. Complete the details on the **GSM System Account Creation** screen including your contact details and valid Sealite GSM Product Serial Number, and click **Submit**

Sealite
www.sealite.com

Home Publications Gallery About Us

SEARCH

Home > Sales & Enquiries > GSM System Account Creation

GSM System Account Creation

Sealite offers free on-line accounts to the owners of our GSM Monitoring series products. Use this page to create an account.

Once you have an account, log-in to this website and register each of your GSM lights. Then, you can view all your GSM light data in one place, at a glance, including historical data and graphs of performance. Of course, this does not interfere with your ability to check individual light data at will via your mobile phone SMS.

What would you like to do?

- Sign up to our news bulletin
- Order a catalogue
- Request a quote
- Technical assistance
- Register a product warranty
- Become a distributor

Please note: account creation is automated. A valid Sealite GSM product serial-number is required to authenticate your application. Invalid or missing codes will automatically be rejected.

Important: please submit this form once only then wait for your confirmation email. Do not repeat this process for each GSM light you own. You will be able to register all your lights after you receive your password.

First Name * Last Name *

Company or Business Name Job Title

Choose your user name * Valid GSM Product Serial Number *

Check User Name

Address line 1 * Address line 2

Phone * Mobile

City, Town or Suburb *

Fax -

Email * Confirm Email *

Subscribe to email updates?

SUBMIT

Sealite
www.sealite.com

Head Office : +61(0)3 5977 6128
USA & Canada : +1 (603) 737 1311
UK : +44 (0) 1502 588026

YOUR EMAIL ADDRESS **SUBSCRIBE**

© 2014 All rights reserved. Contact Us

**Successful submissions
will display the
message below.**

Your request for an on-line GSM account has been sent successfully. Please check your email for your account details and further instructions. If your account details do not arrive within 1 hour, please check your email junk folder. If still no success, please DO NOT re-submit the form. You will need to contact Sealite for assistance. Regards from the Sealite Team

3. Check your email account for confirmed secure login details.

From: info@sealite.com.au

To:

Cc:

Subject: Details of your new account login for Sealite Web site [Scanned]

[This email contains login details for your new account at Sealite Web site This email is automatically generated - PLEASE DO NOT REPLY TO THIS EMAIL.]

Your account details are as follows:
User Name:
Password:

To use your account, go to <http://www.sealite.com.au/> and login via the link "Registered Users" at the top of the home page. You will be able to change your password at this time or any time in the future if you wish

LOG INTO YOUR GSM ACCOUNT

4. Go to **www.sealite.com** on the internet, select the **Technical** tab, then select **GSM Portal**.

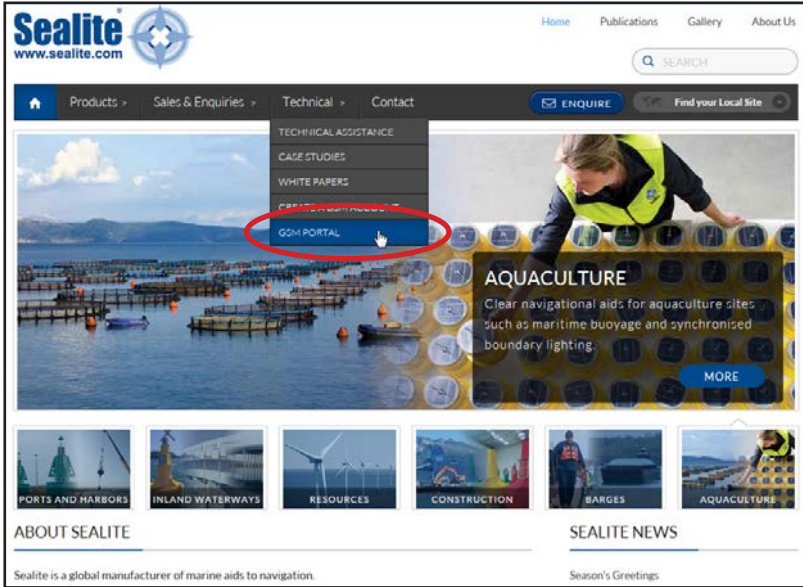

5. Complete your login details.

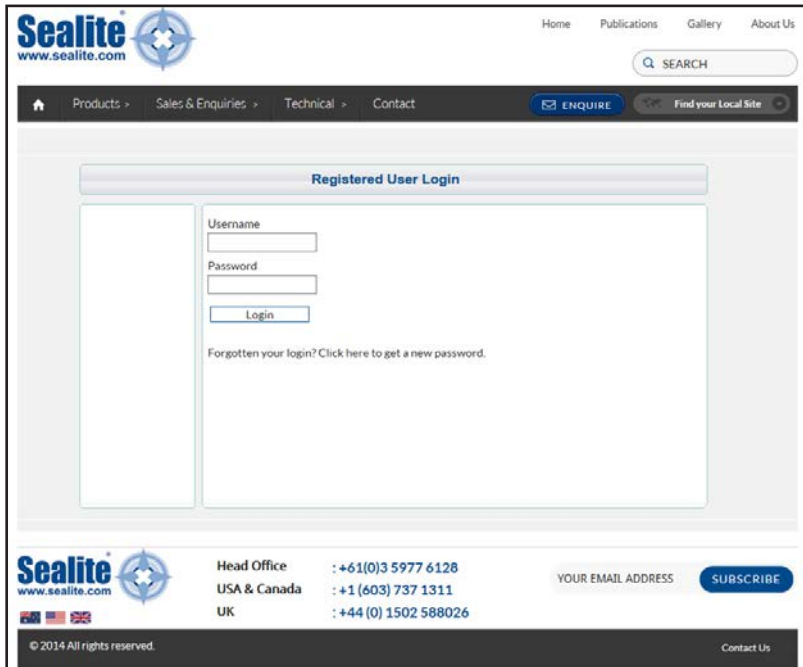

GSM Dashboard

Once logged in, you will come to the **GSM Dashboard** page.

Sealite
www.sealite.com

Home Publications Gallery About Us

SEARCH

Home Products > Sales & Enquiries > Technical > Contact ENQUIRE Find your Local Site

WELCOME you are logged in as LOG OUT

GSM Dashboard

- Dashboard
- Configuration Table
- Deployment Map
- Change Password
- HELP!!
- Log Out

Configuration Table

See critical light data in summary table view
Drill down on each light to view all data
Add or remove GSM lights
Enable & configure alarm messaging
Enable & configure daily reports

Deployment Map

See entire GSM light network in map view
Click on icons to see summary data
Drill down on each light to view all data

Change Password

Change your Password

Request Help

Access a help request form
Get personal assistance with GSM

Head Office : +61(0)3 5977 6128
USA & Canada : +1(603) 737 1311
UK : +44 (0) 1502 588026

YOUR EMAIL ADDRESS SUBSCRIBE

© 2014 All rights reserved. Contact Us

This page has menus you can use to navigate your way around Sealite's GSM Web Portal where you can perform a variety of tasks such as adding or removing GSM lanterns, viewing your lantern installations on a map, view critical lantern data or request help.

You can easily return to this page at any time by selecting **Dashboard** in the menu on the left of the page.

CONFIGURATION

The **Configuration Table** menu of the **GSM Dashboard** enables you to do the following:

- See critical lantern data in summary table view
- Drill down on each lantern to view all data
- Add or remove GSM lanterns
- Enable & configure alarm email messaging
- Enable & configure daily email reports

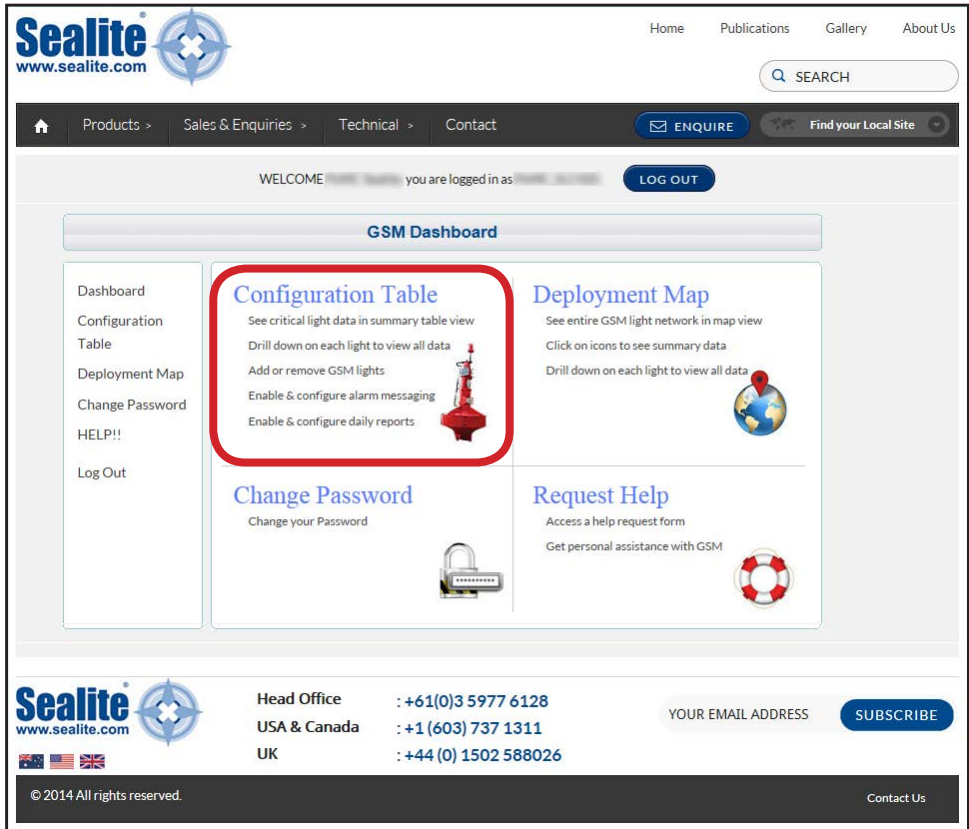

The screenshot shows the Sealite website's GSM Dashboard. At the top left is the Sealite logo and navigation links: Home, Publications, Gallery, About Us. A search bar is on the top right. Below the navigation is a dark bar with 'ENQUIRE' and 'Find your Local Site' buttons. A welcome message and 'LOG OUT' button are centered. The main content area is titled 'GSM Dashboard' and contains four menu items: 'Dashboard', 'Configuration Table', 'Deployment Map', 'Change Password', and 'HELP!!'. The 'Configuration Table' item is highlighted with a red box and includes a list of actions: 'See critical light data in summary table view', 'Drill down on each light to view all data', 'Add or remove GSM lights', 'Enable & configure alarm messaging', and 'Enable & configure daily reports'. Other items include 'Deployment Map' (with a globe icon), 'Change Password' (with a lock icon), and 'Request Help' (with a lifebuoy icon). The footer contains the Sealite logo, contact information for Head Office, USA & Canada, and UK, a 'SUBSCRIBE' button, and a copyright notice.

Add GSM Lanterns

To register your lantern with Sealite’s secure online web reporting system you need to add it to your account:

1. Select **Configuration Table** from the **GSM Dashboard** or select **Configuration Table** in the menu on the left of the page.
2. Click on **ADD+**
This can be found at the bottom right of the table.

The screenshot shows the Sealite web application interface. At the top left is the Sealite logo and website URL. The top right has navigation links: Home, Publications, Gallery, About Us, and a search bar. Below this is a dark navigation bar with links for Products, Sales & Enquiries, Technical, and Contact, along with an ENQUIRE button and a Find your Local Site dropdown. A welcome message indicates the user is logged in as 'lantern.Chen'. A LOG OUT button is present. The main content area is titled 'Configuration' and contains a table with columns: Phone, Name, Type, Flash Code, Min Volts, Alarms, Reports, and an empty column. Below the table is an 'add unit...' link and an 'ADD+' button, which is highlighted by a red arrow. A red message above the table states: 'Before our database can begin recording data for your GSM units, each individual unit must be registered here.' The footer includes the Sealite logo, contact information for Head Office, USA & Canada, and UK, a SUBSCRIBE button, and copyright information.



For lantern data to be updated daily in the Sealite GSM Web Reports, users must first send the SMS text message command “add alarm web” to the designated lantern(s).

3. The following page will appear on your screen.

Sealite
www.sealite.com

Home Publications Gallery About Us

SEARCH

Products > Sales & Enquiries > Technical > Contact

ENQUIRE Find your Local Site

WELCOME you are logged in as LOG OUT

Add/Edit GSM Unit

Dashboard
Configuration
Table
Deployment Map
Change Password
HELP!!
Log Out

1. Identify
Phone numbers and a meaningful name are required.
IDENTIFY UNIT
Country Number
IDENTIFYING NAME
Coordinate Picker
Lat: Lat in degrees:
Long: Long in degrees:

2. Configure
Enabling alarms will cause you to receive an email if this unit triggers an alarm.
Alarms can be sent to up to 3 email addresses.
ENABLE ALARM EMAILS
Enabling reports will cause you to receive an email report from this unit daily.
Reports can be sent to up to 3 email addresses.
ENABLE REPORT EMAILS

3. Process Submit Cancel

Sealite
www.sealite.com

Head Office : +61(0)3 5977 6128
USA & Canada : +1 (603) 737 1311
UK : +44 (0) 1502 588026

YOUR EMAIL ADDRESS SUBSCRIBE

© 2014 All rights reserved. Contact Us

4. Fill in the details of your lantern:

Identify: Enter the lantern's individual cell-phone number and identifying name.
It is suggested that the name of the lantern be descriptive for easy identification.

5. Activate Alarm emails

Configure: ENABLE ALARM EMAILS

Check this box if you wish to receive an email if this lantern triggers an alarm.

Enter the email addresses of the personnel that you wish to receive alarm messages.

You can enter the email addresses of up to 2 additional recipients.

If an alarm is triggered an email will be sent to these addresses.

2. Configure

Enabling alarms will cause you to receive an email if this unit triggers an alarm.
Alarms can be sent to up to 5 email addresses.

ENABLE ALARM
EMAILS

←

ALARM EMAIL 1 (default email for this account, see "My Details")

example@sealite.com

ALARM EMAIL 2

ALARM EMAIL 3

ALARM EMAIL 4

ALARM EMAIL 5



For lantern alarm data to be sent to the Sealite GSM Web Portal when triggered, users must first send the SMS text message command to the lantern to set up the particular alarm required.

5. Activate Report emails

Configure: ENABLE REPORT EMAILS

Check this box if you wish to receive an email report from this lantern daily. Enter the email addresses of the personnel that you wish to receive daily reports. You can enter the email addresses of up to 2 additional recipients.

Process:

Click the **Submit** button to register your lantern. Data for your lantern will be available approximately 24 hours from the time the lantern is put into actual service or powered up.

2. Configure

Enabling alarms will cause you to receive an email if this unit triggers an alarm.
Alarms can be sent to up to 5 email addresses.

ENABLE ALARM
EMAILS

ALARM EMAIL 1 (default email for this account, see "My Details")
example@sealite.com

ALARM EMAIL 2

ALARM EMAIL 3

ALARM EMAIL 4

ALARM EMAIL 5

3. Process

4. The following screen will appear to inform you that your update was processed successfully.

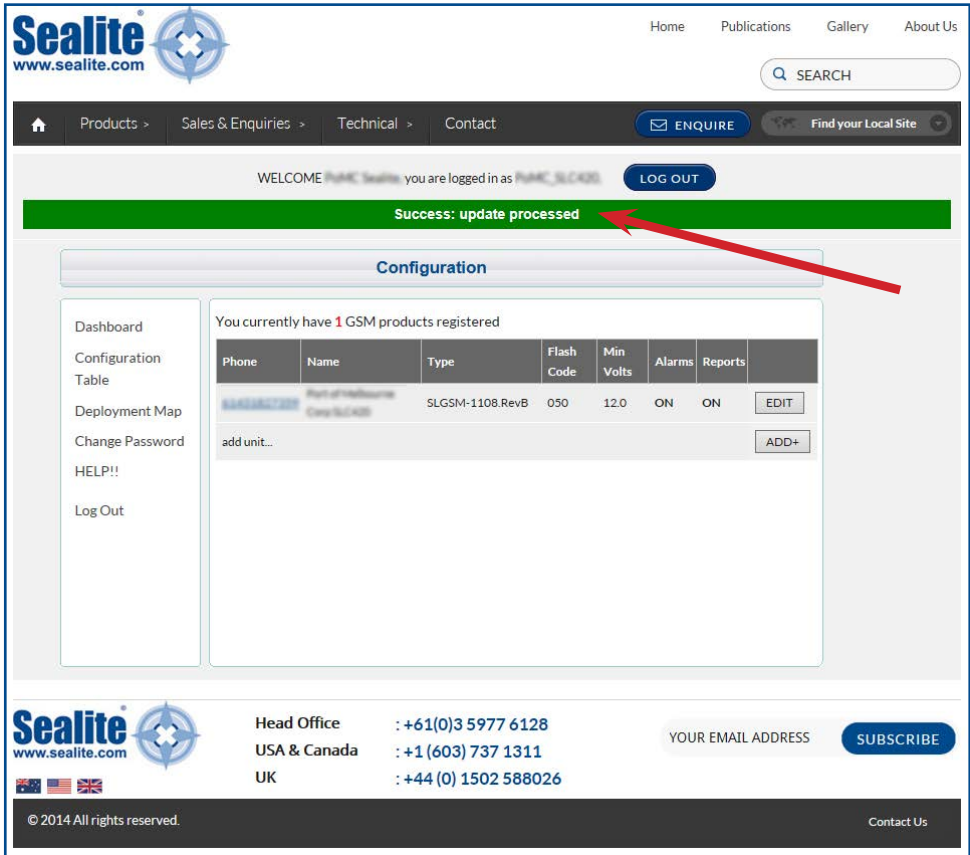

The screenshot shows the Sealite web application interface. At the top left is the Sealite logo and website URL. The top right contains navigation links: Home, Publications, Gallery, and About Us. Below this is a search bar and a navigation menu with links for Products, Sales & Enquiries, Technical, and Contact. A dark blue bar contains an ENQUIRE button and a 'Find your Local Site' dropdown. A user login bar shows 'WELCOME P/M/C Sealite, you are logged in as P/M/C SLG08' with a LOG OUT button. A prominent green banner displays the message 'Success: update processed', with a red arrow pointing to it from the right. Below the banner is a 'Configuration' section header. On the left is a sidebar menu with options: Dashboard, Configuration Table, Deployment Map, Change Password, HELP!!, and Log Out. The main content area shows 'You currently have 1 GSM products registered' and a table with the following data:

Phone	Name	Type	Flash Code	Min Volts	Alarms	Reports	
848888220	Port of Melbourne Data SLG08	SLGSM-1108.RevB	050	12.0	ON	ON	EDIT
add unit...							ADD+

At the bottom of the page, there is a footer with the Sealite logo, contact information for Head Office (+61(0)3 5977 6128), USA & Canada (+1 (603) 737 1311), and UK (+44 (0) 1502 588026). It also includes a subscription form with a 'SUBSCRIBE' button and a 'Contact Us' link. The copyright notice '© 2014 All rights reserved.' is located in the bottom left corner.

Remove GSM Lanterns

To remove a lantern:

1. Select **Configuration Table** from the **GSM Dashboard** or select **Configuration Table** in the menu on the left of the page.
2. Locate the lantern you wish to remove and click on **EDIT** (this appears to the right of the lantern).
3. Click the **Delete** button at the bottom of the page to remove the selected lantern.

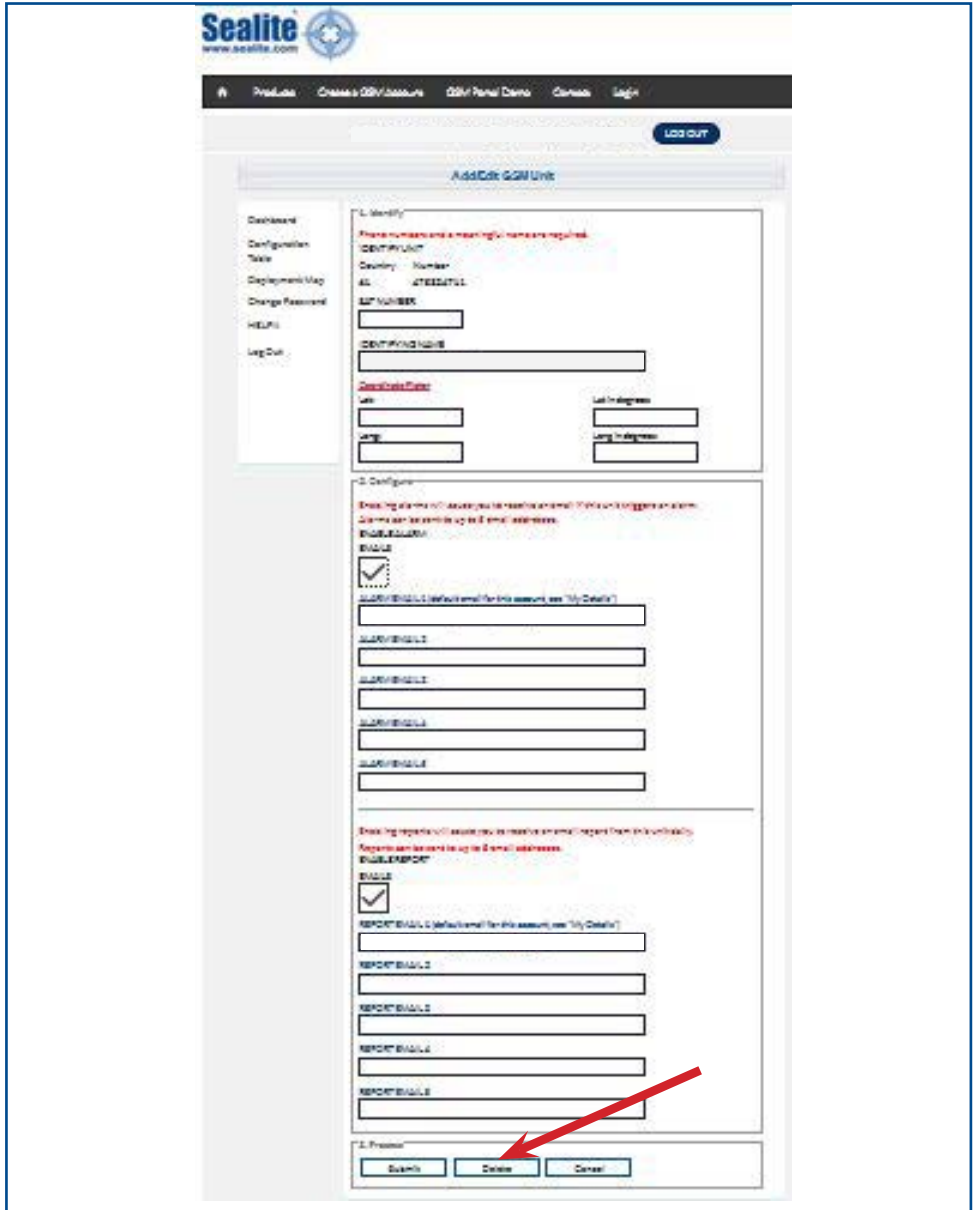

The screenshot displays the Sealite web application interface. At the top, there is a navigation bar with links for 'Previous', 'Create a GSM Account', 'GSM Panel Demo', 'Contact', and 'Login'. A 'LOG OUT' button is located in the top right corner. The main content area is titled 'Add/Edit GSM Unit'. On the left side, there is a sidebar menu with options: 'Dashboard', 'Configuration Table', 'Deployment Map', 'Change Password', 'HELP', and 'Log Out'. The main form is divided into three sections:

- 1. Identify:** This section contains a red error message: 'Phone numbers and meaningful names are required.' Below this are input fields for 'IDENTIFY UNIT', 'Country: Number', 'AL: ATTEESTAL', 'GSM NUMBER', and 'IDENTIFY NAME'. There is also a 'Cancel/Save Filter' button.
- 2. Configure:** This section contains a red error message: 'Please log in to the account you are trying to use. This unit triggers an alarm. Some can be set to log up to 8 email addresses.' Below this is a 'ENABLE' checkbox (checked), a 'REPORT EMAIL' (default email for this account, see 'My Details') field, and several empty input fields for additional email addresses.
- 3. Preview:** This section contains another red error message: 'Please log in to the account you are trying to use. Report from this unit will. Reports can be sent to up to 8 email addresses.' Below this is another 'ENABLE' checkbox (checked), a 'REPORT EMAIL' (default email for this account, see 'My Details') field, and several empty input fields for additional email addresses.

At the bottom of the form, there are three buttons: 'Submit', 'Delete', and 'Cancel'. A red arrow points to the 'Delete' button.

See Critical Lantern Data in Summary View Table

This will take you to a new page with a summary listing of all your GSM lanterns registered in the system.

1. Select **Configuration Table** from the **GSM Dashboard** or select **Configuration Table** in the menu on the left of the page.
2. The following table summary will appear:

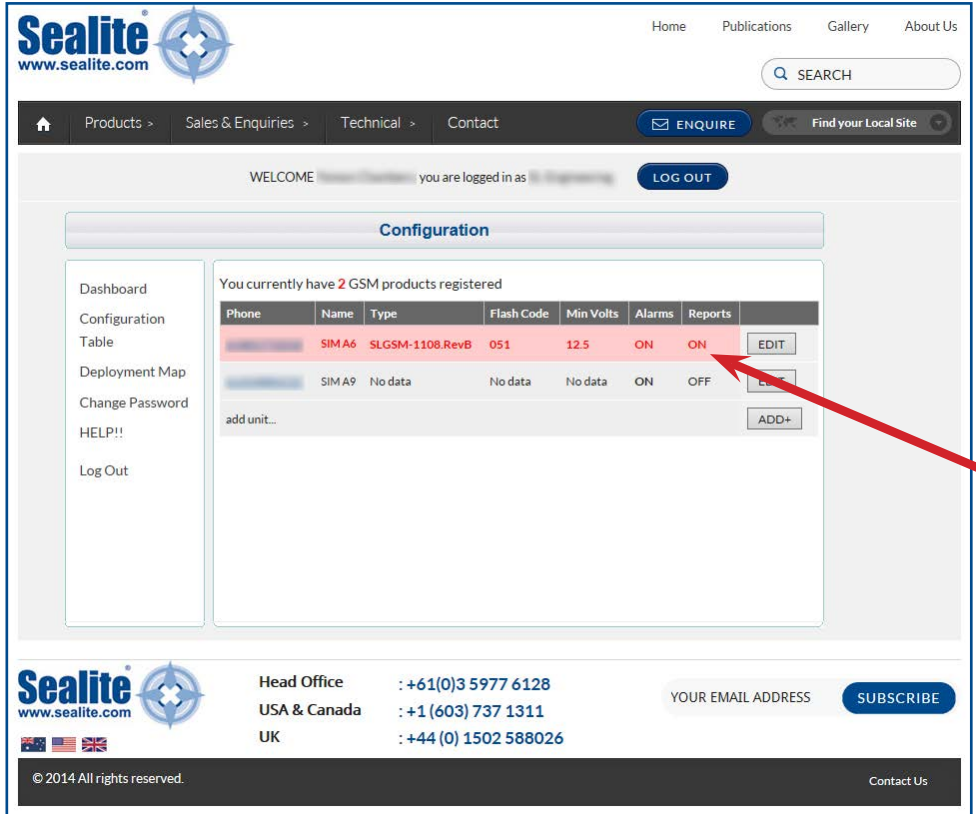

The screenshot shows the Sealite Configuration Table interface. The table lists registered GSM products. The first row is highlighted in red, indicating an alarm condition. A red arrow points to the 'Reports' column of the first row.

Phone	Name	Type	Flash Code	Min Volts	Alarms	Reports	
	SIMA6	SLGSM-1108.RevB	051	12.5	ON	ON	EDIT
	SIMA9	No data	No data	No data	ON	OFF	EDIT
add unit...							ADD+

3. The background colour of a particular lantern will change to a red colour if an alarm condition is present.

Drill Down on Each Lantern to View All Data

This will take you to a new page showing detailed information for the GSM lantern selected.

1. Select **Configuration Table** from the **GSM Dashboard** or select **Configuration Table** in the menu on the left of the page.
2. The following table summary will appear:

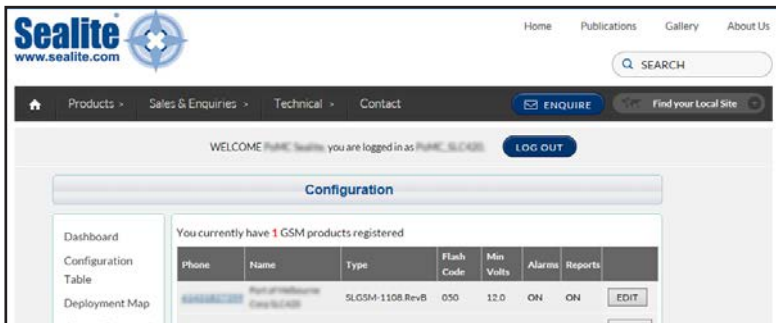

3. Click the cell-phone number of the lantern you wish to view in more detail.
4. The following detailed report for the lantern will appear in a new window.
Breaks in the data represent periodic absence of data transmission or removal of lantern for servicing.

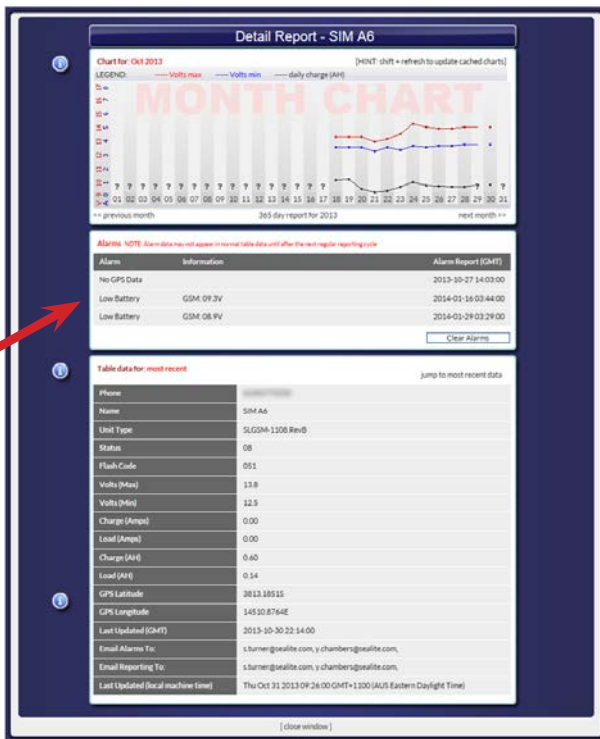

Lantern with an alarm

5. For help viewing detailed information about Charts, Data and Email Reporting click on the 'i' button to the left of the screen:

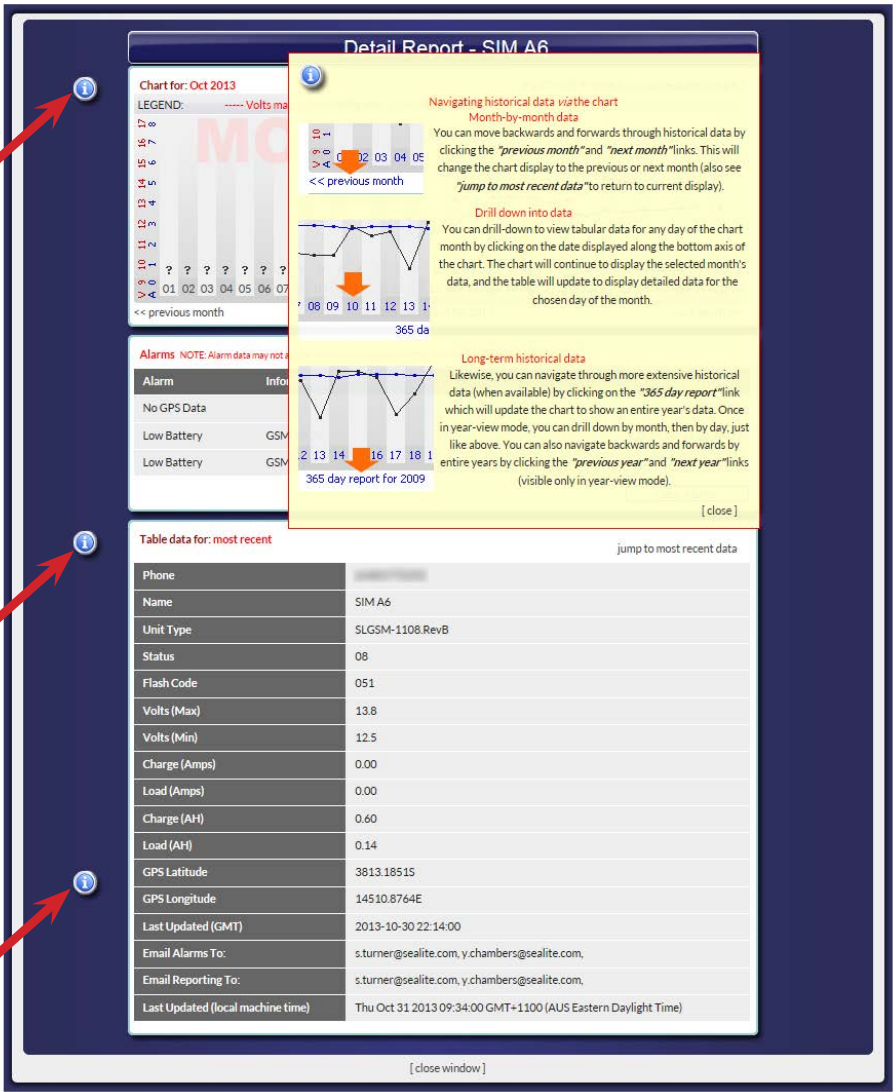

Chart help

Data help

Email reporting help

Detail Report - SIM A6

Chart for: Oct 2013
LEGEND: ----- Volts ma

Alarms NOTE: Alarm data may not be accurate

Alarm	Info
No GPS Data	
Low Battery	GSM
Low Battery	GSM

Table data for: most recent

Phone	
Name	SIM A6
Unit Type	SLGSM-1108.RevB
Status	08
Flash Code	051
Volts (Max)	13.8
Volts (Min)	12.5
Charge (Amps)	0.00
Load (Amps)	0.00
Charge (AH)	0.60
Load (AH)	0.14
GPS Latitude	3813.18515
GPS Longitude	14510.8764E
Last Updated (GMT)	2013-10-30 22:14:00
Email Alarms To:	s.turner@sealite.com, y.chambers@sealite.com,
Email Reporting To:	s.turner@sealite.com, y.chambers@sealite.com,
Last Updated (local machine time)	Thu Oct 31 2013 09:34:00 GMT+1100 (AUS Eastern Daylight Time)

jump to most recent data

[close]

[close window]

DEPLOYMENT MAP

The **Deployment Map** section of the **GSM Dashboard** enables you to do the following:

- See entire GSM lantern network in map view
- Click on items to see summary data
- Drill down on each lantern to view all data

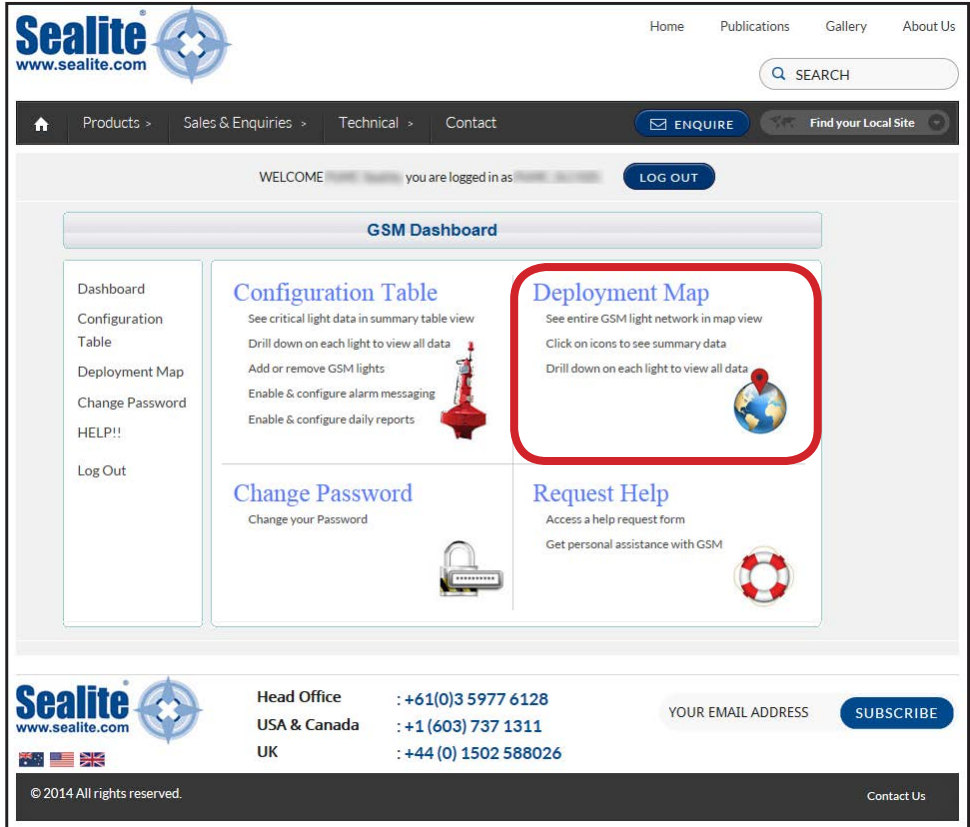

Sealite
www.sealite.com

Home Publications Gallery About Us

SEARCH

Home Products > Sales & Enquiries > Technical > Contact ENQUIRE Find your Local Site

WELCOME you are logged in as LOG OUT

GSM Dashboard

Dashboard
Configuration
Table
Deployment Map
Change Password
HELP!!
Log Out

Configuration Table
See critical light data in summary table view
Drill down on each light to view all data
Add or remove GSM lights
Enable & configure alarm messaging
Enable & configure daily reports

Deployment Map
See entire GSM light network in map view
Click on icons to see summary data
Drill down on each light to view all data

Change Password
Change your Password

Request Help
Access a help request form
Get personal assistance with GSM

Sealite
www.sealite.com

Head Office : +61(0)3 5977 6128
USA & Canada : +1 (603) 737 1311
UK : +44 (0) 1502 588026

YOUR EMAIL ADDRESS SUBSCRIBE

© 2014 All rights reserved. Contact Us

This allows you to view the location of your GSM Lantern installations via map.

1. Select **Deployment Map** from the **GSM Dashboard** or select **Deployment Map** in the menu on the left of the page.
2. A map of your GSM lanterns will appear with the Sealite Logo indicating the location of your installation(s). Use the zoom in/out tool bar at the top left of the page to navigate around the map.
3. To see summary data for a specific lantern, click on the Sealite icon on the map. A call-out box appears on the map with the summary data of the lantern.
4. The Sealite Logo will be highlighted in red if an alarm condition occurs.
4. To drill down on the lantern to view all data, click on **View Full Details** in the call-out box and a new window will open displaying detailed information about the lantern.

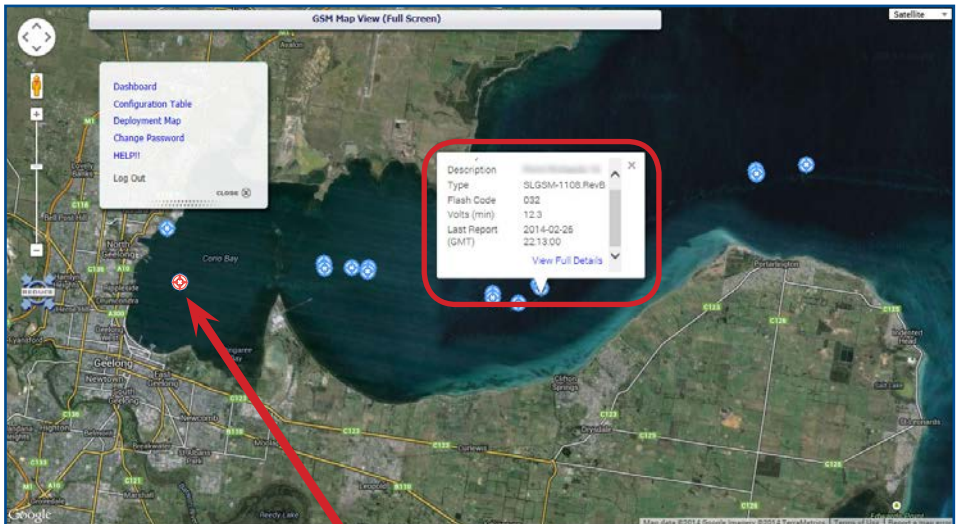

Lantern with an alarm condition

REQUEST HELP

The **Request Help** menu of the **GSM Dashboard** enables you to submit a form to Sealite to request assistance from a Sealite GSM expert.

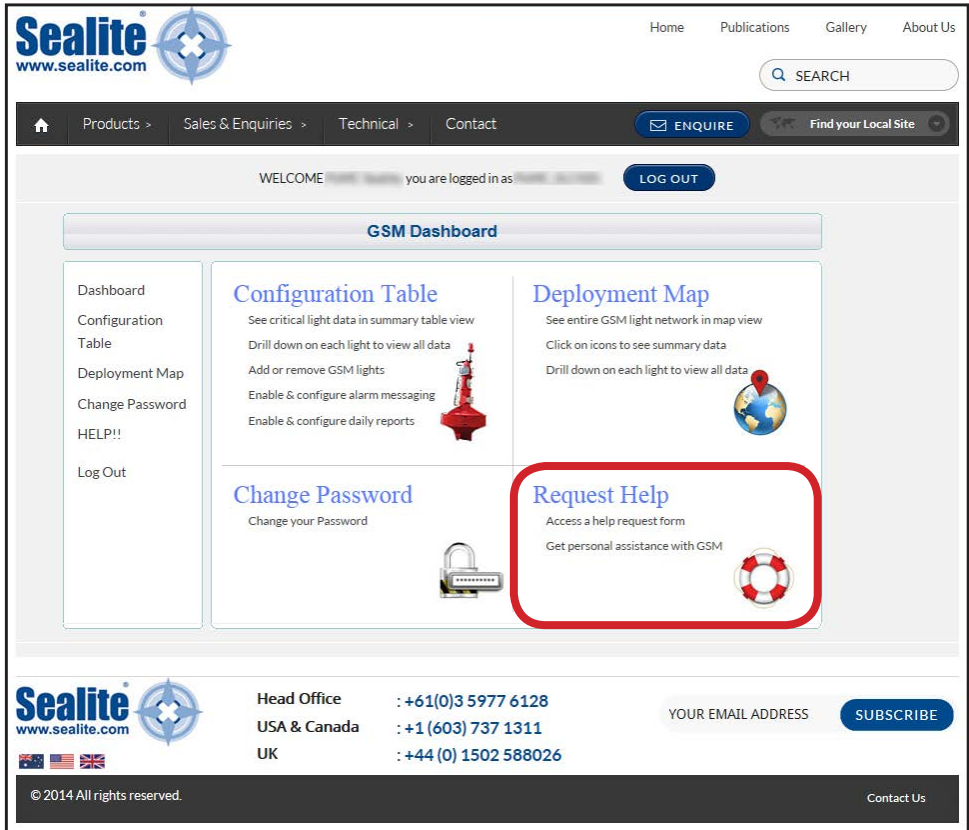

The screenshot shows the Sealite website interface. At the top left is the Sealite logo and navigation links: Home, Publications, Gallery, About Us. A search bar is on the top right. Below the navigation is a dark menu bar with links: Home, Products >, Sales & Enquiries >, Technical >, Contact, ENQUIRE, and Find your Local Site. A welcome message and a LOG OUT button are visible. The main content area is titled "GSM Dashboard" and contains several sections:

- Dashboard**: A sidebar menu with links to Dashboard, Configuration Table, Deployment Map, Change Password, HELP!!, and Log Out.
- Configuration Table**: A section with a red lighthouse icon. Text includes: "See critical light data in summary table view", "Drill down on each light to view all data", "Add or remove GSM lights", "Enable & configure alarm messaging", and "Enable & configure daily reports".
- Deployment Map**: A section with a globe icon. Text includes: "See entire GSM light network in map view", "Click on icons to see summary data", and "Drill down on each light to view all data".
- Change Password**: A section with a padlock icon. Text includes: "Change your Password".
- Request Help**: A section with a lifebuoy icon, highlighted by a red rounded rectangle. Text includes: "Access a help request form" and "Get personal assistance with GSM".

At the bottom of the page, there is contact information for Head Office, USA & Canada, and UK, along with a subscription form and a copyright notice: © 2014 All rights reserved.

1. Select **Request Help** from the **GSM Dashboard** or select **HELP!!** in the menu on the left of the page.
2. The following form will appear.
3. Complete the details.
4. Click **Submit**

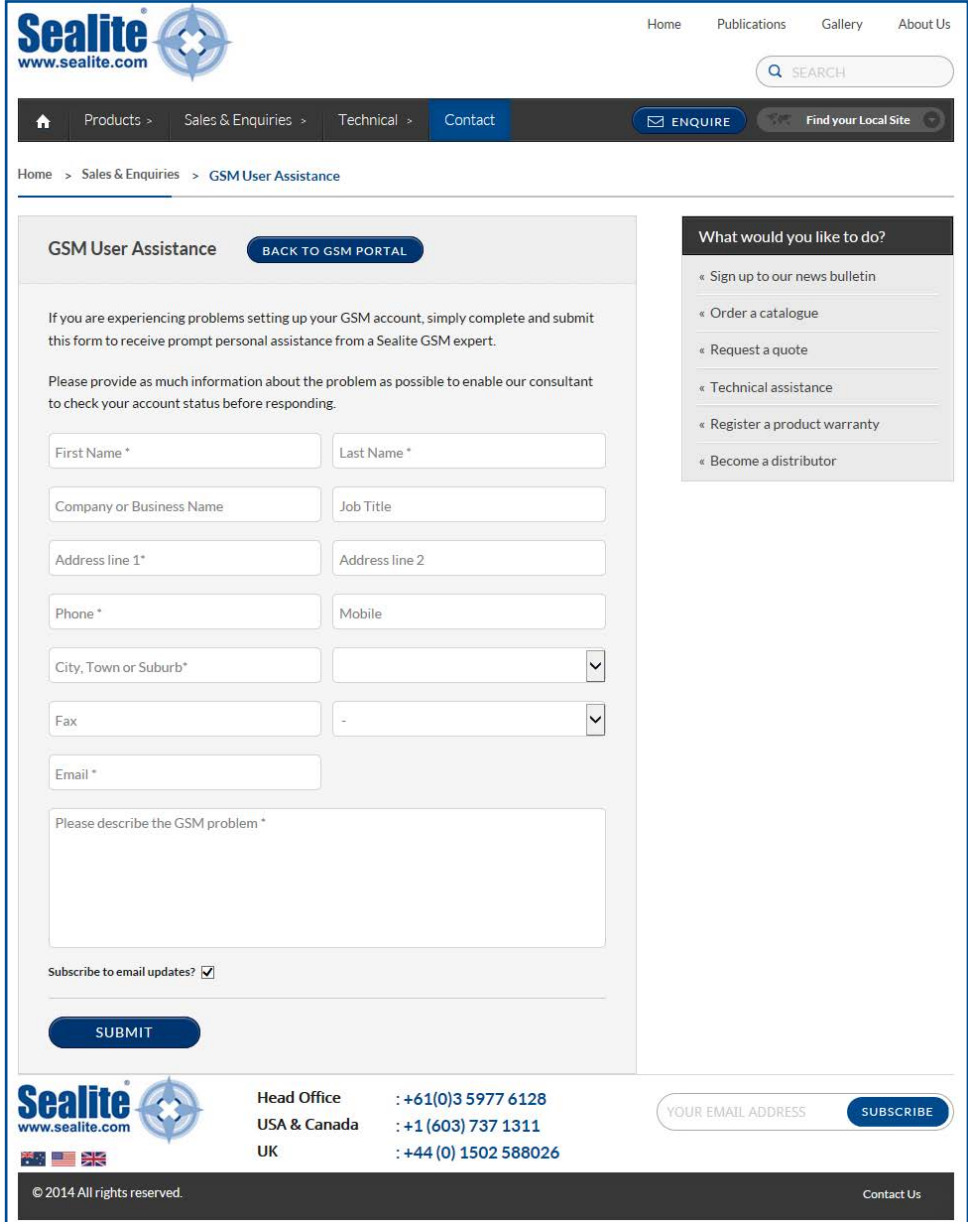

Sealite
www.sealite.com

Home Publications Gallery About Us

SEARCH

Products > Sales & Enquiries > Technical > **Contact** ENQUIRE Find your Local Site

Home > Sales & Enquiries > **GSM User Assistance**

GSM User Assistance [BACK TO GSM PORTAL](#)

If you are experiencing problems setting up your GSM account, simply complete and submit this form to receive prompt personal assistance from a Sealite GSM expert.

Please provide as much information about the problem as possible to enable our consultant to check your account status before responding.

First Name * Last Name *

Company or Business Name Job Title

Address line 1* Address line 2

Phone * Mobile

City, Town or Suburb*

Fax -

Email *

Please describe the GSM problem *

Subscribe to email updates?

SUBMIT

What would you like to do?

- « Sign up to our news bulletin
- « Order a catalogue
- « Request a quote
- « Technical assistance
- « Register a product warranty
- « Become a distributor

Sealite
www.sealite.com

Head Office : +61(0)3 5977 6128
USA & Canada : +1 (603) 737 1311
UK : +44 (0) 1502 588026

YOUR EMAIL ADDRESS **SUBSCRIBE**

© 2014 All rights reserved. Contact Us

CHANGE PASSWORD

The **Change Password** menu of the **GSM Dashboard** enables you to change your password:

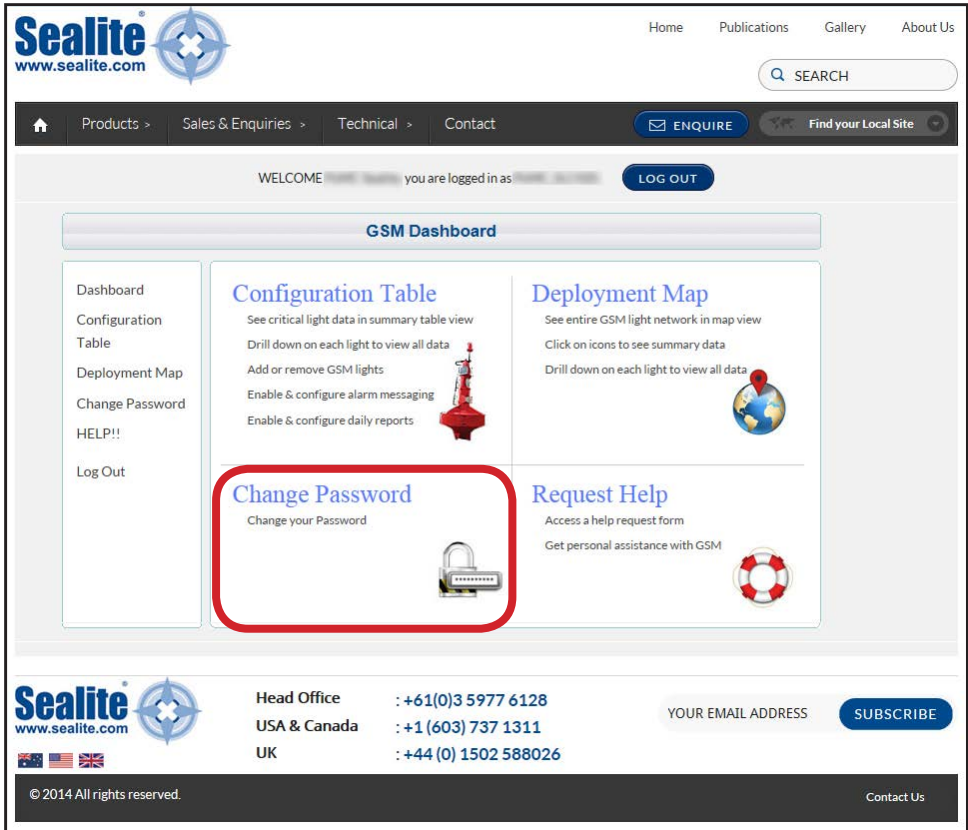

The screenshot shows the Sealite GSM Dashboard interface. At the top left is the Sealite logo and website address. Navigation links include Home, Publications, Gallery, and About Us. A search bar is located on the right. Below the navigation is a dark bar with a home icon, menu items (Products, Sales & Enquiries, Technical, Contact), an ENQUIRE button, and a Find your Local Site dropdown. A welcome message indicates the user is logged in, with a LOG OUT button. The main content area is titled "GSM Dashboard" and contains a sidebar menu on the left with options: Dashboard, Configuration Table, Deployment Map, Change Password, HELP!!, and Log Out. The "Change Password" option is highlighted with a red rounded rectangle. The main content area is divided into four sections: Configuration Table (with a red light icon), Deployment Map (with a globe icon), Change Password (with a padlock icon), and Request Help (with a lifebuoy icon). At the bottom, there is contact information for Head Office, USA & Canada, and UK, along with a subscription form and a copyright notice for 2014.

1. Select **Change Password** from the **GSM Dashboard** or select **Change Password** in the menu on the left of the page.
2. Complete the details.
3. Click **Submit**

The screenshot shows the Sealite web application interface. At the top left is the Sealite logo and website URL. The top right contains navigation links: Home, Publications, Gallery, and About Us, along with a search bar. Below this is a dark navigation bar with a home icon, menu items (Products, Sales & Enquiries, Technical, Contact), an ENQUIRE button, and a Find your Local Site dropdown. The main content area displays a welcome message: "WELCOME PoMC Sealite, you are logged in as [username]". A "LOG OUT" button is circled in red. Below the welcome message is a "Password Change" form. The form has a left sidebar with navigation links: Dashboard, Configuration, Table, Deployment Map, Change Password, HELP!!, and Log Out. The main form area is titled "Change Password for user: [username]". It contains fields for "Current password", "New Password", and "Confirm new password". The "New Password" field has a help icon. Below the fields are "Submit" and "Cancel" buttons. The footer contains the Sealite logo, contact information for Head Office, USA & Canada, and UK, a "SUBSCRIBE" button, and copyright information.

REMEMBER TO LOG OUT WHEN YOU HAVE FINISHED VIEWING YOUR GSM LANTERN DATA

(click "LOG OUT" at the top right of the page)



Trouble Shooting

Initial Setup

The most important step in the process of setting up your GSM monitoring and control module is to ensure desired cell phone numbers are programmed into the access list.

Use the list access command (see “Sending Commands” on page 20) to confirm cell phone numbers are correctly entered. Re-enter from a correctly listed cell phone the numbers required.

If the initial access list number(s) are incorrectly entered, lost, or if the lantern’s cell phone number will not respond, power up the lantern and email Sealite technicians (info@sealite.com) the following details:

- Designated Lantern SIM Card Number
- Country Code
- Lantern Serial Number **

*** Please Note: A charge may be levied for this service*

Web Reporting

If no data is available from your secure web login after following the outlined procedure:

- Send the SMS text message “list alarm” to check that the alarm to the web has is enabled
- If the alarm has been enabled, then re-send the SMS text message “add web +61418569242” to ensure the gateway is open.

Trouble Shooting Table

Problem	Remedy
Lantern will not activate.	<ul style="list-style-type: none"> • Ensure lantern is in darkness. • Wait at least 60 seconds for the program to initialise in darkness. • Ensure switch setting is on a valid code (not unused flash code). • Ensure battery terminals are properly connected. • Ensure battery voltage is above 12volts.
Timing codes will not change.	<ul style="list-style-type: none"> • Turn rotary switches several times to ensure contacts are clear.
Lantern will not operate for the entire night.	<ul style="list-style-type: none"> • Expose lantern to direct sunlight and monitor operation for several days. Sealite products typically require 3 hours of direct sunlight per day to retain full autonomy. From a discharged state, the lantern may require several days of operational conditions to 'cycle' up to full autonomy. • Reducing the light output intensity or duty cycle (flash code) will reduce current draw on the battery. • Ensure solar module is clean and not covered by shading during the day. • Reduce the GSM Mode to Slow. This will reduce current draw on the battery.
My lantern won't respond to the 1st message I send on setup.	<ul style="list-style-type: none"> • Ensure SIM card is active, has credit, and is fitted correctly. • Ensure there is no PASSWORD on the SIM card account and the SIM Card is unlocked.
My SMS reports are sometimes showing N/A or reports that "no data" has been received.	<ul style="list-style-type: none"> • This indicates that the GPS or battery charge at night is not available. Otherwise the lantern may have failed therefore responding with a reading of "N/A" (not available). Contact Sealite for further help.
When I send an SMS there is no SMS response from the lantern within 5-20 minutes.	<ul style="list-style-type: none"> • The cell phone monitoring system is reliant on cell phone coverage and gateway traffic, and may suffer from occasional drop outs, or the lantern may be located in a marginal GSM coverage area (check with your local network provider for coverage details). One or all of these parameters affect the performance of your monitoring system. • The GSM implements a sleep cycle to save power. Under normal conditions the GSM will be put to sleep for 15 minutes at a time. • Your phone is not listed in either the Report or Access list. If you try to send a Get or Set command, the Lantern will reply with the following message "Unknown Command"
When I send an SMS there is no response.	<ul style="list-style-type: none"> • Please make sure you are listed on the Access or Report List. • Check the number you are ringing from is listed in the access list or the report list. • Try sending the SMS from a different phone using a different network.
Lantern response is "Unknown Command"	<ul style="list-style-type: none"> • The GSM has not recognised the command. Refer to Command section of this manual to ensure a valid texted message has been sent to the GSM. • The GSM allows up to 10 occurrences of this response in any 24 hour period. Additional invalid commands will not trigger a response until the commencement of the next 24hr period. • Please make sure you are listed on the Access or Report List.
My lantern does not appear on the web portal	<ul style="list-style-type: none"> • Send the SMS text message "list alarm" to check that the alarm to the web has is enabled • If the alarm has been enabled, then re-send the SMS text message "add web +61418569242" to ensure the gateway is open

Lantern Board Indicator / Status LED's

There are two status LED's located on the master circuit board.

The red status LED is used to indicate the health of the lantern's power system, eg battery voltage. The Yellow status LED is used to indicate the operational status of the lantern. These indicator LEDs can be viewed through the side of the base of the lantern.

Yellow LED	Lantern Status	Lantern	Comment
OFF	Normal	OFF	Lantern is in Daylight and in Dusk till Dawn mode or in Standby Mode
Flashing ON 0.15 seconds OFF 0.15 seconds	Normal	OFF	Light is activating and will turn on after detecting 30 seconds of continuous darkness.
Flashing 2 x quick flashes every 2 seconds (Heartbeat)	Normal	ON	Lantern is in Normal operating condition. It is not connected to any GPS synchronisation.
Flashing ON 1.5 seconds OFF 1.5 seconds	Normal	ON	Normal operating condition. Lantern is synchronised to GPS-enabled lanterns.
Flashing 1 x quick flash every 2 seconds	Normal	ON	Lantern is 're-syncing' with GPS. The lantern re-sync's with the GPS every 15 minutes.
Flashing 2 x quick flashes every 11 seconds	Normal	ON	Lantern is a Hard Wire Synchronisation Slave.

Red LED	Lantern Status	Lantern	Comment
OFF	Normal		Normal Battery Voltage
Flashing once every 1.6 seconds	Battery Voltage is 12 – 12.5V		Battery Voltage is between 12 – 12.5V
Flashing twice every 2 seconds	Battery Voltage is 11.5 – 12V		Battery Voltage is between 11.5 – 12V
Flashing 3 x times every 2 seconds	Battery Voltage is 10.5 – 11.5V		Battery Voltage is between 10.5 – 11.5V
Flashing 4 x times every 2.5 seconds	Battery Voltage is 10.0 – 10.5V		Battery Voltage is between 10.0 – 10.5V
Flashing 5 x times every 3 seconds	Battery Voltage is less than 10.0V		Battery Voltage is at less than 10.0V
Fixed-on	Flat Battery (<10V)	OFF	Flat Battery cut-off is now operational and the lantern will be off. Battery must receive charge (above 12V) and lantern must see daylight for at least 1 minute before resuming normal operation.
Flashing ON 1.5 seconds OFF 1.5 seconds	Battery Voltage is above 13.5V		Battery Voltage is above 13.5V. this may indicate a problem with the solar regulator.

Phone Module Indicator / Status LED's

The GSM board is fitted with a number of Indicator LED's. Use the diagram below to help determine operational status.

To view Indicator LED's follow the steps shown on in the "Installing a SIM Card" section of this manual

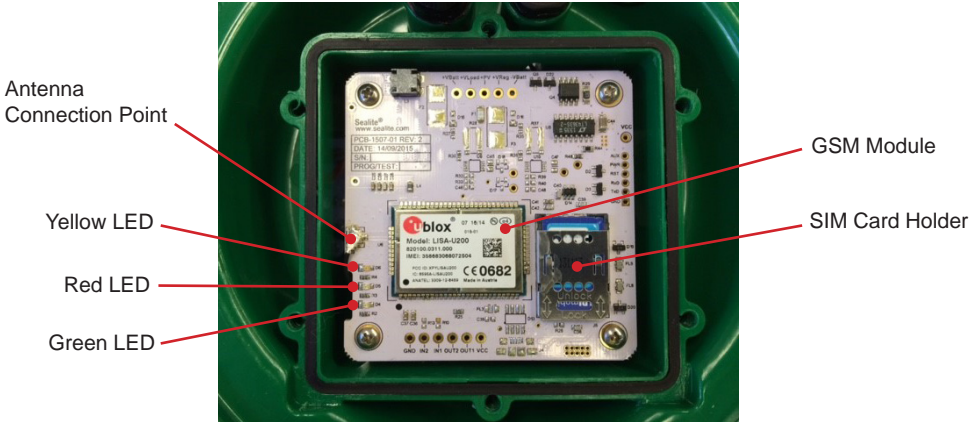

LED Combinations			Condition
Green LED	Red LED	Yellow LED	
The initial setup process takes approximately 1 minute. The below sequence is what you will see after power is connected.			
Slow	Off	Off	The GSM module is in the process of being setup. (Approx. 30Seconds)
1 Quick	1 Quick	Off	The GSM module setup is complete. The SIM card is being setup and is now ready for operation. (Approx. 15 seconds) GSM Signal is not ready
1 Quick	1 Quick	Slow	The GSM module setup is complete. The SIM card is ready for operation. The network signal is being calculated by the GSM Module (Approx. 5 seconds)
1 Quick	1 Quick	1 Quick (Low) 2 Quick (OK) 3 Quick (Good) 4 Quick (Max)	The GSM module setup is complete. The SIM card is ready for operation. The network is ready. The yellow status LED indicates signal strength.
2 Quick	Off	Off	GSM Module setup is complete and the GSM module is asleep. The GSM Module enters Sleep Mode after 5 minutes of operation. It wakes up after 15 minutes in Normal Mode.
During the initial setup process, faults may be found with the SIM Card, Network Signal or GSM Module itself. The table below shows these faults and how the Status LED's will indicate a fault..			
Steady	Off	Off	The setup of the GSM module has failed. Check that the module is present. Reset the unit and try again. <i>Note: The unit will automatically reset within 1</i>
Slow	Steady	Steady	The GSM module is in the process of being setup. The SIM card has failed. These lights will flash for 10 seconds before the unit enters Sleep Mode. Check that the SIM card is present and inserted correctly. Try cleaning the contacts in the SIM Card Holder and cleaning the SIM Card to fix.
1 Quick	1 Quick	Steady	The GSM module setup is complete. The SIM card is ready for operation. The signal is not detectable. Check that the antenna is present and connected to the GSM module.
1 Quick	1 Quick	Slow	The GSM module setup is complete. The SIM card is ready for operation. The network is NOT ready.

Appendix

Wiring Diagrams

GSM Stand Alone using a Sun Saver-10L Solar Regulator

CAUTION:- Under no circumstances connect a GPS/GSM lantern's black solar measurement lead directly to the battery. Doing so will damage the lantern and void all warranties.

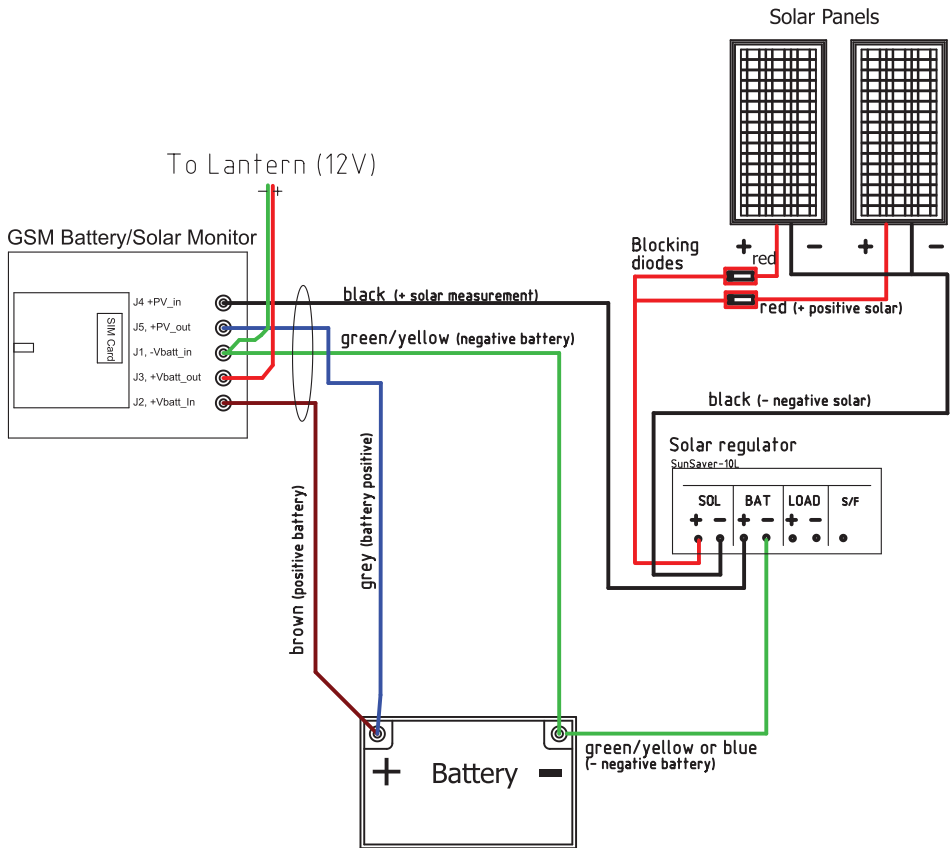

SL-125/SL-155 GSM Lantern using a Sun Saver-10L Solar Regulator

CAUTION:- Under no circumstances connect a GPS/GSM lantern's black solar measurement lead directly to the battery. Doing so will damage the lantern and void all warranties.

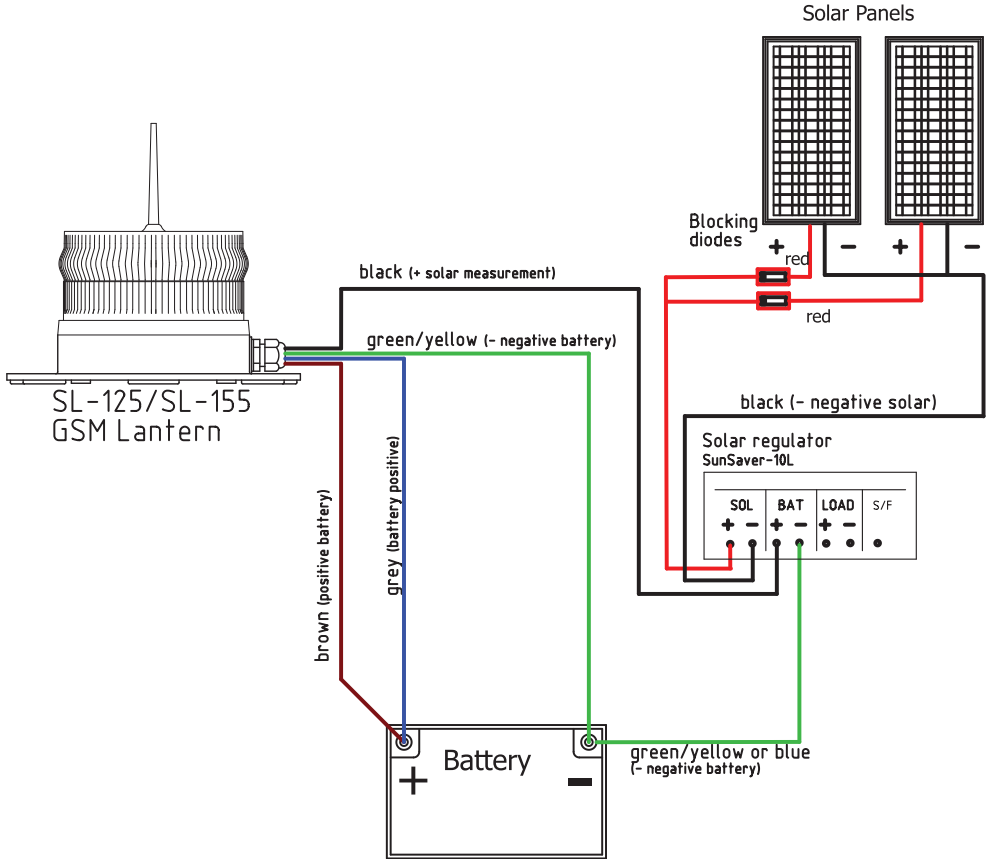

SL-125/SL-155 GSM Lantern using a Sealite-REG-10 Solar Regulator

CAUTION:- Under no circumstances connect a GPS/GSM lantern's black solar measurement lead directly to the battery. Doing so will damage the lantern and void all warranties.

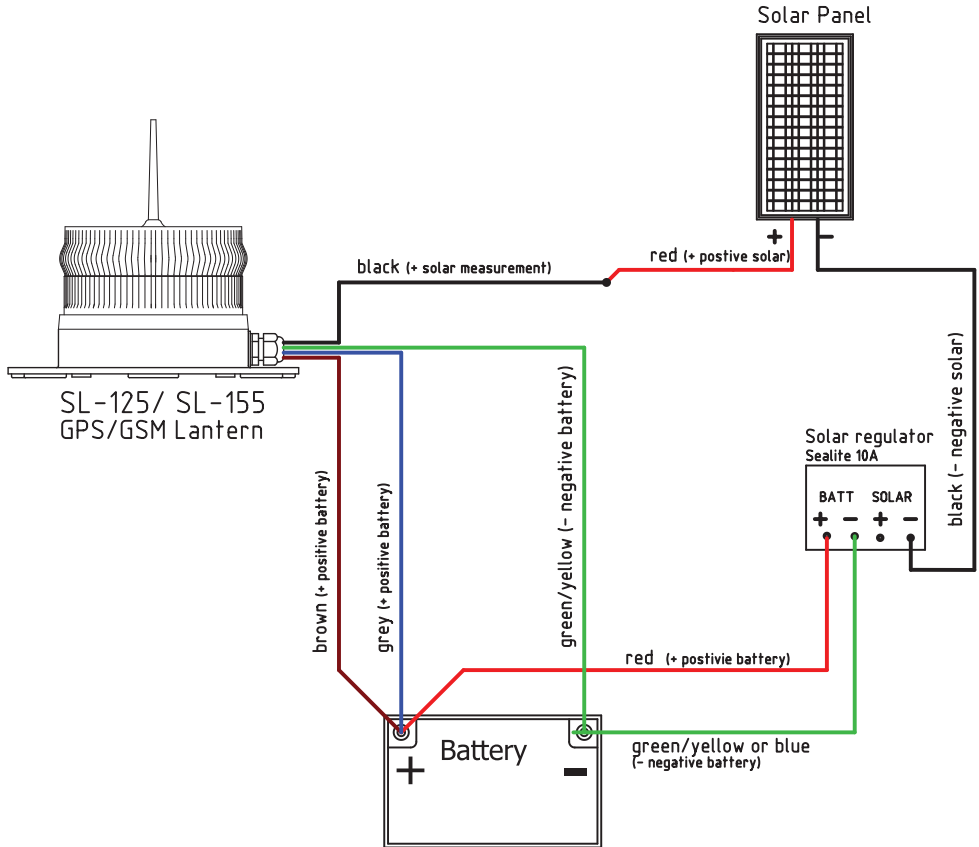



Sealite LED Light Warranty V2.2

Activating the Warranty

Upon purchase, the Sealite Pty Ltd warranty must be activated for recognition of future claims. To do this you need to register on-line. Please complete the Online Registration Form at:

www.sealite.com

Sealite Pty Ltd will repair or replace your LED light in the event of electronic failure for a period of up to three years from the date of purchase, as per the terms & conditions below.

Sealite Pty Ltd will repair or replace any ancillary or accessory products in the event of failure for a period of up to one year from the date of purchase, as per the terms & conditions below.

The unit(s) must be returned to Sealite freight prepaid.

Warranty Terms

1. Sealite Pty Ltd warrants that any Sealite marine products fitted with telemetry equipment including but not limited to AIS, GSM, GPS or RF ("Telemetry Products") will be free from defective materials and workmanship under normal and intended use, subject to the conditions hereinafter set forth, for a period of twelve (12) months from the date of purchase by the original purchaser.
2. Sealite Pty Ltd warrants that any BargeSafe™ Series of LED barge light products ("BargeSafe™ Products") will be free from defective materials and workmanship under normal and intended use, subject to the conditions hereinafter set forth, for a period of twelve (12) months from the date of purchase by the original purchaser.
3. Sealite Pty Ltd warrants that any LED area lighting products ("Area Lighting Products") but not including sign lighting products will be free from defective materials and workmanship under normal and intended use, subject to the conditions hereinafter set forth, for a period of twelve (12) months from the date of purchase by the original purchaser.
4. Sealite Pty Ltd warrants that any ancillary products and accessories, not mentioned in other clauses in this section, will be free from defective materials and workmanship under normal and intended use, subject to the conditions hereinafter set forth, for a period of twelve (12) months from the date of purchase by the original purchaser.
5. Sealite Pty Ltd warrants that any LED sign lighting products ("Sign Lighting Products") will be free from defective materials and workmanship under normal and intended use, subject to the conditions hereinafter set forth, for a period of three (3) years from the date of purchase by the original purchaser.
6. Sealite Pty Ltd warrants that any Sealite marine lighting products other than the Telemetry Products, BargeSafe™ Products, and Area Lighting Products ("Sealite Products") will be free from defective materials and workmanship under normal and intended use, subject to the conditions hereinafter set forth, for a period of three (3) years from the date of purchase by the original purchaser.
7. Sealite Pty Ltd will repair or replace, at Sealite's sole discretion, any Telemetry Products, BargeSafe™ Products, Area Lighting Products or Sealite Products found to be defective in material and workmanship in the relevant warranty period so long as the Warranty Conditions (set out below) are satisfied.
8. If any Telemetry Products, BargeSafe™ Products, Area Lighting Products or Sealite Products are fitted with a rechargeable battery, Sealite Pty Ltd warrants the battery will be free from defect for a period of one (1) year when used within original manufacturer's specifications and instructions.
9. Buoy products are covered by a separate 'Sealite Buoy Warranty'.

Warranty Conditions

This Warranty is subject to the following conditions and limitations;

1. The warranty is applicable to lanterns manufactured from 1/1/2009.
2. The warranty is void and inapplicable if:
 - a. the product has been used or handled other than in accordance with the instructions in the owner's manual and any other information or instructions provided to the customer by Sealite;
 - b. the product has been deliberately abused, or misused, damaged by accident or neglect or in being transported; or
 - c. the defect is due to the product being repaired or tampered with by anyone other than Sealite or



- authorised Sealite repair personnel.
3. The customer must give Sealite Pty Ltd notice of any defect with the product within 30 days of the customer becoming aware of the defect.
 4. Rechargeable batteries have a limited number of charge cycles and may eventually need to be replaced. Typical battery replacement period is 3-4 years. Long term exposure to high temperatures will shorten the battery life. Batteries used or stored in a manner inconsistent with the manufacturer's specifications and instructions shall not be covered by this warranty.
 5. No modifications to the original specifications determined by Sealite shall be made without written approval of Sealite Pty Ltd.
 6. Sealite lights can be fitted with 3rd party power supplies and accessories but are covered by the 3rd party warranty terms and conditions.
 7. The product must be packed and returned to Sealite Pty Ltd by the customer at his or her sole expense. Sealite Pty Ltd will pay return freight of its choice. A returned product must be accompanied by a written description of the defect and a photocopy of the original purchase receipt. This receipt must clearly list model and serial number, the date of purchase, the name and address of the purchaser and authorised dealer and the price paid by the purchaser. On receipt of the product, Sealite Pty Ltd will assess the product and advise the customer as to whether the claimed defect is covered by this warranty.
 8. Sealite Pty Ltd reserves the right to modify the design of any product without obligation to purchasers of previously manufactured products and to change the prices or specifications of any product without notice or obligation to any person.
 9. Input voltage shall not exceed those recommended for the product.
 10. Warranty does not cover damage caused by the incorrect replacement of battery in solar lantern models.
 11. This warranty does not cover any damage or defect caused to any product as a result of water flooding or any other acts of nature.
 12. There are no representations or warranties of any kind by Sealite or any other person who is an agent, employee, or other representative or affiliate of Sealite, express or implied, with respect to condition of performance of any product, their merchantability, or fitness for a particular purpose, or with respect to any other matter relating to any products.

Limitation of Liability

To the extent permitted by acts and regulations applicable in the country of manufacture, the liability of Sealite Pty Ltd under this Warranty will be, at the option of Sealite Pty Ltd, limited to either the replacement or repair of any defective product covered by this Warranty. Sealite will not be liable to Buyer for consequential damages resulting from any defect or deficiencies.

Limited to Original Purchaser

This Warranty is for the sole benefit of the original purchaser of the covered product and shall not extend to any subsequent purchaser of the product.

Miscellaneous

Apart from the specific warranties provided under this warranty, all other express or implied warranties relating to the above product is hereby excluded to the fullest extent allowable under law. The warranty does not extend to any lost profits, loss of good will or any indirect, incidental or consequential costs or damages or losses incurred by the purchaser as a result of any defect with the covered product.

Warrantor

Sealite Pty Ltd has authorised distribution in many countries of the world. In each country, the authorised importing distributor has accepted the responsibility for warranty of products sold by distributor. Warranty service should normally be obtained from the importing distributor from whom you purchased your product. In the event of service required beyond the capability of the importer, Sealite Pty Ltd will fulfil the conditions of the warranty. Such product must be returned at the owner's expense to the Sealite Pty Ltd factory, together with a photocopy of the bill of sale for that product, a detailed description of the problem, and any information necessary for return shipment.

Other Sealite Products Available



**Marine Lanterns
(1-19NM)**



**Monitoring
& Control Systems**



Bridge & Barge Lights



**Marine Buoys
(up to 3mt in diameter)**



Area Lighting



**Mooring Systems
& Accessories**