

2600mm dia. Ocean Buoy

ATLANTIC-2600



ATLANTIC-2600 standard model

IALA top mark

Guard rail

316-grade stainless steel ladder & grab rail

Optional battery compartment

Lifting points

Non slip deck

Rotationally-moulded to 18mm wall thickness

Twin mooring points

ATLANTIC-2600-ET Model shown includes extended tower to 4.0mtr

Optional self-contained lantern

Internal 10m² radar reflector

Convenient tether points

Additional payload

Made from strong, durable, UV-stabilised, virgin polyethylene

Internal tie-bars to interconnect lifting & mooring points

Innovative guidance keel

The Sealite Advantage

- Able to be transported globally in a standard shipping container
- High visibility red, green, white or yellow as per IALA recommendations
- Internal redundant buoyancy system
- 316-grade stainless steel, moulded-in tie bars provide outstanding lifting strength
- Excellent buoyancy & stability
- Easy to deploy & service
- No painting, ever
- Lower cost & environmentally friendly

The ATLANTIC-2600 is a 2.6mtr diameter navigation buoy designed for offshore port and coastal applications.

The buoy is rotationally-moulded by Sealite from UV-stabilised virgin polyethylene, and has a 2.6mtr float diameter and up to 4.0mtr lantern focal height.

The ATLANTIC-2600 is built in a 5-part modular design and can be setup in any IALA recommended assembly.

Twin lifting and mooring eyes are interconnected by stainless steel tie bars through the hull structure – offering enormous strength and superior longevity of the navaid.

The ATLANTIC buoy is the only buoy in its class to offer a large 2.6mtr diameter float section without the incorporation of a central mooring post. This provides enormous user benefits, including;

- Faster, easier to assemble – the ATLANTIC-2600 buoy is delivered almost ready to deploy
- Lightweight – up to 60% lighter than competitor models
- Single, rotationally-moulded main float section
- All stainless steel fittings



The hull section of the ATLANTIC-2600 has detachable side panels that are designed to be removed during transport, allowing the buoy to be conveniently transported in a shipping container. This provides the benefits of an extraordinarily large float section, without the need for a heavy, steel mooring-post.



Environmentally Friendly & Recyclable

Sealite buoy products are made from recyclable materials. As a service to customers, individual components and products at the end of their service life may be returned to Sealite for recycling.

2600mm dia. Ocean Buoy

ATLANTIC-2600

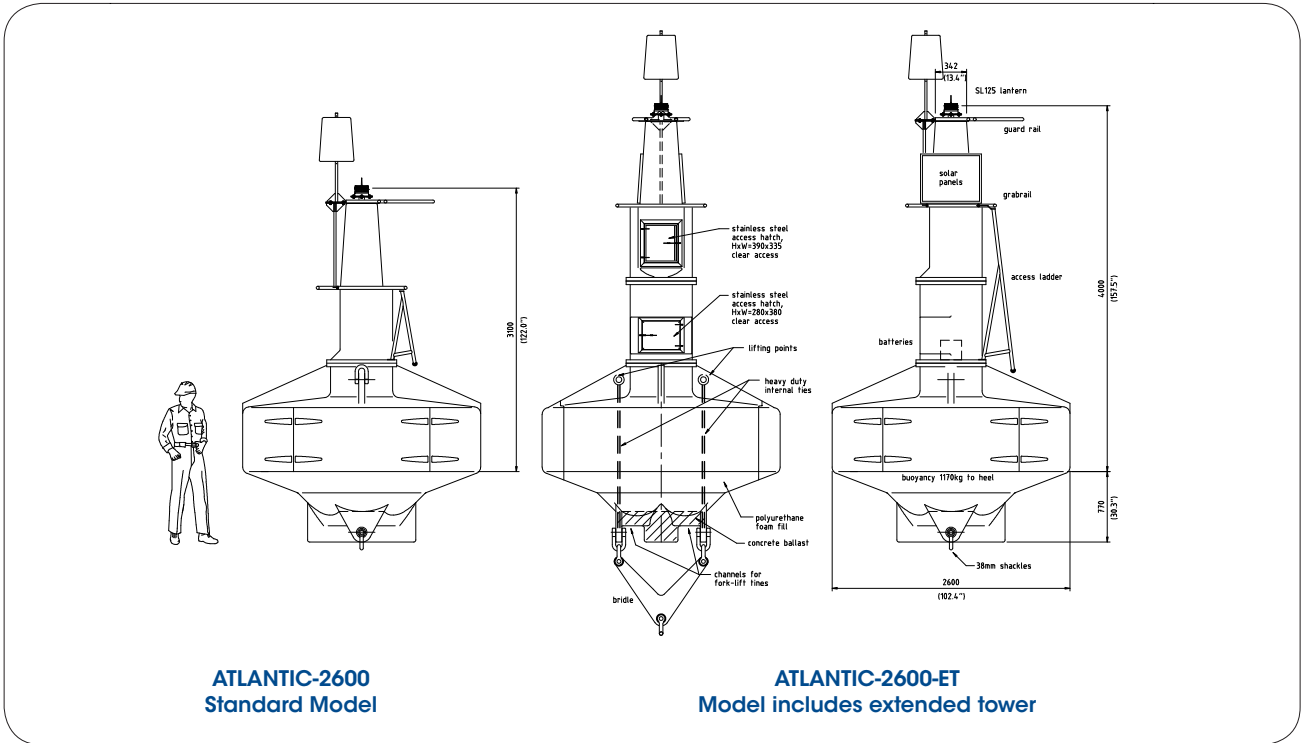

SPECIFICATIONS * *

ATLANTIC-2600

General Characteristics

Available Colours
Focal Plane Height (mm/inches)

Total Float Volume (ltrs/US gallon)
Nominal Freeboard (mm/inches)
Nominal Draught (mm/inches)
Reserve Buoyancy (kgs/lbs)
Maximum Mooring Load (kgs/lbs)

Draught, Maximum (mm/inches)
Freeboard, Minimum (mm/inches)
Safe Working Load, 1pt (kgs/lbs)
Safe Working Load, 2pt (kgs/lbs)
Submergence (kg/cm, lb/inches)
Visual Area (m²/ft²)

Physical Characteristics

Material

Wall Thickness (mm/inches)
Ballast (kg/lbs)
Filling
Height (mm/inches)

Width (mm/inches)
Mass (kg/lbs)
Radar Reflector
Product Life Expectancy

Certifications

IALA
Quality Assurance

Intellectual Property

Trademarks

Warranty *

Lantern Options
Options Available

Red, Green, White, Yellow as per IALA Recommendations
ATLANTIC-2600 (standard model): 3100 / 122
ATLANTIC-2600-ET (extended tower model): 4000 / 157¹/₂
5610 / 1482
780 / 30³/₄
690 / 27¹/₄
1475 / 3252
1475 / 3252
Must lift with 2 points when mooring load as above 1050 / 2315
960 / 37³/₄
510 / 20¹/₈
1950 / 4300
5200 / 11460
54.7 / 306
4.0 / 13.1

Rotationally-moulded UV-stabilised virgin polyethylene,
316-grade internal tie bars, lifting & mooring eyes
18 / ³/₄ (float section)

400 / 882 internal concrete
Closed-cell polyurethane foam (float section)
ATLANTIC-2600 Standard Model: 4120 / 162¹/₄
ATLANTIC-2600-ET: 5020 / 197⁵/₈

2600 / 102³/₈
970 / 2138
Echomax
>20 years

Surface colours compliant to IALA E-108
ISO9001:2008

SEALITE® is a registered trademark of Sealite Pty Ltd
5 years

Sealite SL-C310, SL-C410, SL-C415, SL-C420, SL-125 Series or SL-155 Series
• Mould-in graphics
• Day marks
• Monitoring Systems (AIS, GSM)

* Specifications subject to change or variation without notice
* Subject to standard terms and conditions



Sealite
www.sealite.com



Sealite Pty Ltd
Australia
t: +61 (0)3 5977 6128

Sealite Asia Pte Ltd
Singapore
t: +65 6829 2243

Sealite United Kingdom Ltd
UK
t: +44 (0) 1502 588026

Sealite USA LLC
USA
t: +1 (603) 737 1311